

DAFTAR PUSTAKA

- Abdelghani, E. dan Hassanuddeen, Abd Aziz. (2012). The Relationship Between Religiosity and Customer Adaption of Islamic Services in Marocco. Oman: Arabian. *Journal of Business & Management Review*, Vol. 1, No. 9.
- Abdul Mukti Soma, Ina Primiana, Sudarso K Wiryono, Erie Febrian, (2017), Religiosity and Islamic Banking Product Decision: Survey on Employees Of PT Telekomunikasi Indonesia, *Etikonomi*, Vol. 17. No. 1, h. 53-67
- Abdul Mukti Soma., Ina Primiana., Sudarso K. Wiryono., dan Erie Febrian. (2017). Religiosity And Islamic Banking Product Decision: Survey On Employees Of Pt Telekomunikasi Indonesia, *Etikonomi*, Vol. 16, No.1,h. 25-42
- Adji, Jennifer dan Samuel, Hatane. (2014). Pengaruh Satisfaction dan Trust Terhadap Minat Beli Konsumen (Purchase Intention) di Starbuck the Square Surabaya, *Jurnal Strategi Pemasaran* Vol. 2, No. 1
- Agus, Yulianto, (2017), *Bank Syariah Mau Maju Pesat?Kaafah Jawabannya!*, Kompas
- Ahmadi, Abu. (2007). Psikologi Sosial. Jakarta; Rineka Cipta.
- Aji, D. S. K., Setyawati, S. M., & Rahab, R. (2020). Analisis Pengaruh Religiosity, Service Quality dan Image Terhadap Customer Loyalty dengan Trust Sebagai Mediasi. *Jurnal Ekonomi, Bisnis Dan Akuntansi (JEBA)*, 22(1), 78–94.
- Akbar, Yason Taufik. (2019). *60 Persen Rekening Masyarakat Aceh masih di Bank Konvensional*, <https://tribunnews.com>
- Alam, S. S., Janor, H., Zanariah, Wel, C. A., & Ahsan, M. N. (2012). Is Religiosity an Important Factor in Influencing the Intention to Undertake Islamic Home Financing in Klang Valley? *World Applied Sciences Journal*, 19(7), 1030-1041
- Alfi Mulikhah Lestari, (2017), Pengaruh Religiusitas, Produk Bank, Kepercayaan, Pengetahuan, Dan Pelayanan Terhadap Preferensi Menabung Pada Perbankan Syariah (Studi Kasus Pada Mahasiswa Fakultas Ekonomi dan Bisnis Universitas Brawijaya Malang, *Jurnal Ilmiah*,
- Al-Hyari, K., Alnsour, M., Al-Weshah, G., & Haffar, M. (2012). Religious beliefs and consumer behaviour: From loyalty to boycotts. *Journal of Islamic Marketing*, 3(1), 155–174.

- Amin, H., Abdul Rahman, A., & Ramayah, T. What makes undergraduate students enroll into an elective course? The case of Islamic accounting. *International Journal of Islamic and Middle Eastern Finance and Management*, 2(4), 289-304. 2009
- Amin, H., Rahman, A. R., Sondoh Jr, S. L., & Ang, M. C. (2011). Determinants of customers' intention to use Islamic personal financing: The case of Malaysian Islamic banks. *Journal of Islamic Accounting and Business Research*, 2(1), 22 - 42. doi:10.1108/17590811111129490
- Ancok, D & Suroso, F.N. (2008). *Psikologi Islam: Solusi Islam atas Problem-Problem Psikologi*, Yogyakarta; Pustaka Pelajar
- Antonius Purwanto. 2020. Provinsi Aceh. <https://kompaspedia.kompas.id/baca/profil/daerah/provinsi-Aceh>. Diakses tanggal 20 Juni 2021
- Ardiprawiro. (2013). *Teori Organisasi Umum*. Gunadarma
- Armstrong, Gery dan Philip Kotler. (1995). *Dasar-dasar Pemasaran*. Edisi Keenam. Jakarta: CV Intermedia.
- Arnould, E., Price, L., & Zikhan, G. (2004). *Consumers* (2 ed.). New York: McGraw-Hill.
- Assauri, Sofjan. (2004). *Manajemen Pemasaran*. Jakarta: Rajawali Press
- Astuti. Novi Puji. (2020). *Mengenal Fungsi Bank Syariah, Lengkap dengan Sejarah dan Ciri-cirinya*. www.merdeka.com. Diakses 13 Agustus 2021
- Aydin, S., dan Ozer, G., (2007), National Customer Satisfaction Indices: An Implementation in The Turkish Mobile Telephone Market, *Academy of Marketing Studies Journal*, Vol. 11, No. 1, h. 113-121
- Azra, A. (2000). *Pendidikan Islam: Tradisi dan Modernisasi Menuju Milenium Baru*. Jakarta: Logos,
- Azwar Saefuddi ., (2013). *Sikap Manusia Teori dan Pengukurannya*, Edisi 2, Yogyakarta : Pustaka Pelajar
- Azwar Saefuddin. (1997). *Metode Penelitian*. Jogyakarta: Pustaka Pelajar.

- Azwar, Saefuddin. (2018). *Reliabilitas dan Validitas*, Edisi ke 4, Jakarta: Pustaka Pelajar
- Baiq Handayani Rinuastuti, Sri Darwini, Eka Agustiani, Imanuella Romaputri Andilolo,(2018).<http://distribusi.unram.ac.id/index.php/distribusi/issue/view/8>
- Basu Swastha Dharmmestha. (2005), *Manajemen Pemasaran*, Jakarta: PT. Erlangga
- Bobokhonov, S., & Brito, P. (2015). In travel, discover, marketing. In K. Fam, & P. Brito (Ed.), *5th Proceedings of MAGScholar Global Business, Marketing and Tourism Conference* (pp. 17–25). Asia Business Research Corporation.
- Brockmann, Erich N.; Anthony, William P. (2016). "Tacit knowledge and strategic decision making". *Group & Organization Management*. 27 (4): 436–455. doi:10.1177/1059601102238356.
- Brown, Pam (November 29, 2007), Career coach: decision-making, Pulse, retrieved July 12, 2012 (*subscription required*)
- Buchari Alma, (2011), *Manajemen Pemasaran dan Pemasaran Jasa*, Cetakan. Kesembelian, Alfabeth, Bandung.
- Bustari Muchtar, Rose Rahmidani, dan Menik Kurnia.(2016). *Bank dan Lembaga Keuangan Lainnya*. Jakarta; Kencana
- Cateora, P., & Graham, J. (1999). *International Marketing* (10 ed.). Boston: Irwin/McGraw-Hill.
- Chacter, Daniel L.; Gilbert, Daniel Todd; Wegner, Daniel M. (2011) [2009]. *Psychology* (2nd ed.). New York: Worth Publishers. ISBN 9781429237192. OCLC 755079969.
- Crozier, W. Ray; Ranyard, Rob (1997). "Cognitive process models and explanations of decision making". In Ranyard, Rob; Crozier, W. Ray; Svenson, Ola (eds.). *Decision making: cognitive models and explanations. Frontiers of cognitive science*. London; New York
- Dahar, R.W, (2005), *Teori-Teori Belajar dan Pembelajaran*, Jakarta : Erlangga
- Dahari, Z., Abduh, M., & Fam, K. S. (2015). Measuring service quality in Islamic banking: Importance-performance analysis approach. *Asian Journal of Business Research*, 5(1), 15–28.

- Departemen Agama Republik Indonesia, (2002), *Al-Quran Terjemah Indonesia*, Bandung: Syaamil Al-Qur'an
- Djaali (2008) Djaali. 2008. *Psikologi Pendidikan*. Jakarta: Bumi Aksara.
- Drummond, Helga, (2000), *Pengambilan Keputusan yang Efektif*, Jakarta:PT. Gramedia Pustaka Utama
- Dwi Priyatno, (2009), *5 Jam Belajar Olah Data dengan SPSS 17*. Yogyakarta : PT. Andi
- Earnshaw, E.L. (2000). Religious Orientation and Meaning in Life; An Exploratory Study. Departement of Psychology: Central Modist Collage.
- Essoo, N., & Dibb, S. (2004). Religious influences on shopping behaviour: An exploratory study. *Journal of Marketing Management*, 7(8), 683.
- Fam, K.S, D.S. Waller dan B.Z. Erdogan. (2002). The Influence of Religion on Attitudes Towards the Advertising of Controversial Products. *European Journal of Marketing*, Vol. 38 No. 5, hal. 537-55
- Fandy Tjiptono. (2014), *Pemasaran Jasa: Prinsip, Penerapan dan Penelitian*, Yogyakarta: Andi Offset
- Fazio, R. H. (1986). How do Attitudes Guide Behavior? In R. M. Sorrentino, & E. T. Higgins, *Handbook of Motivation and Cognition: Foundations of Social Behavior*. New York: The Guilford Press
- Ferdinand. (2002). *Metode Penelitian Manajemen: Pedoman penelitian untuk Skripsi, Tesis, dan Desertasi Ilmu Manajemen*, Semarang: Badan Penerbit Universitas Diponegoro
- Flavian dan Giunaliu, Measure on web usability Websites. (2017), *Journal of Computer Information Systems*, No. 48. Issue. 1, hal. 17-123
- Frensch, Peter A.; Funke, Joachim, eds. (1995). Complex problem solving: the European perspective. *Hillsdale, NJ: Lawrence Erlbaum Associates*. ISBN 978-0805813364. OCLC 32131412.
- Fuad Nashori dan Rachmy Diana Mucharam. (2002), *Mengembangkan Kreativitas dalam Perspektif. Psikologi Islam*, Yogyakarta : Menara Kudus

- Gait, A., & Worthington, A. (2009). *A Primer on Islamic Finance: Definitions, Sources, Principles and Methods*. Australia: Department of Accounting, Finance and Economics, Griffith University.
- Gary, A., & Kotler, P. (2010). *Dasar-dasar Pemasaran*. Jilid 1, Alih. Bahasa Alexander Sindoro dan Benyamin Molan. Jakarta: Prehalindo.
- Gerungan, W.A. (1991). *Psikologi Sosial*. Bandung: PT Eresco.
- Glock, C. dan Stark, R.(1996) *Religion and Society In Tension*. Chicago: University of California
- Guo, Kristina L. (2008). "DECIDE: a decision-making model for more effective decision making by health care managers". *The Health Care Manager*. 27 (2): 118–127. doi:10.1097/01.HCM.0000285046.27290.90. PMID 18475113.
- Hadija., Nuriatullah, dan Nurfitriani, (2019). Pengaruh Religiusitas dan Lokasi Terhadap Keputusan Nasabah Memilih BRI Syariah Dalam Transaksi Kredit Kepemilikan Rumah (KPR) Syariah, *Jurnal Ilmu Perbankan dan Keuangan Syariah*, Vol. 1, No. 2,h. 01-20
- Hair, Jr., Joseph.F, et. al.,(1998) *Multivariate Data Analysis. Fifth Edition*. Prentice-Hall, inc., New Jersey.
- Halimah, Cut Nur. (2016) *Problematika SDM Perbankan Syariah*, <https://trinunnews.com>
- Handayani R. Sri Darwini., Eka Agustiani dan Imanuella. (2018). Pengaruh Religiusitas dan Persepsi Nasabah terhadap Keputusan Memilih Bank Syariah.. *Journal Management and Business*, Volume 01, No. 02, h. 46-59
- Handayani R. Sri Darwini., Eka Agustiani dan Imanuella. (2018). Pengaruh Religiusitas dan Persepsi Nasabah terhadap Keputusan Memilih Bank Syariah.. *Journal of Management and Business.Al-Amwal*, Volume 01, No. 02, h. 46-59
- Handayani R., Darwini, Sri., Agustiani, Eka & Imanuella. (2018). Pengaruh Religiusitas Terhadap Perilaku Memilih Bank Syariah Melalui Kepercayaan Merek (Studi Pada Nasabah Bank Syariah di Kota Mataram). *Jurnal Distribusi*. Vol. 6, No. 2. h. 47-59
- Handayani, Heri., Azman, Asri Aulia & Ismail, Ismail. (2019).Pengaruh Pengetahuan dan Sikap Terhadap Perilaku Memilih Bank Syariah Dengan Faktor

Religiusitas Sebagai Moderating Variable. *Journal of Economic Studie*. Vol. 3, No. 1, h.01-09

Handono Lisa. (2004). *Faktor-faktor yang Mempengaruhi Kepercayaan Pelanggan Terhadap Jasa Kontraktor CV. Anugerah Jaya Surabaya*, Malang: Universitas Petra

Hanifah Jasin, Siti Mujiatun, Muis Fauzi Rambe, dan Rahmad Bahagia Siregar, (2021), Apakah Kepercayaan Memediasi Pengaruh Reputasi Bank dan Religiusitas Terhadap Purchase Intention?. *Jurnal Ilmiah Manajemen Dan Bisnis*, Vol. 22.No. 21, h. 86-102

Hanifah Jasin, Siti Mujiatun, Muis Fauzi Rambe, dan Rahmad Bahagia Siregar, (2021), Apakah Kepercayaan Memediasi Pengaruh Reputasi Bank dan Religiusitas Terhadap Purchase Intention?. *Jurnal Ilmiah Manajemen Dan Bisnis*, Vol. 22.No. 21, h. 86-102

Harris, Gaardenia. (2016). Incremental Theory of Decisionmaking. Global Encyclopedia of Public Administration, Public Policy, and Governance. Hlm.1-5. https://doi.org/10.1007/978-3-319-31816-5_2996-1

Harsono (2000), *Teori Sikap dan Perilaku*. Tiara Wacana: Yogyakarta.

Hawari, D. (1996). *Al-Qur'an: Ilmu Kedokteran Jiwa dan Kesehatan Jiwa*. Jakarta: Dana Bhakti Prima Yasa.

Helga, D. (2012). *Metode Penelitian Bisnis*, edisi 5 Jilid 1. Jakarta: Erlangga.

Heri Sudarsono, (2013). *Bank dan Lembaga Keuangan Syariah*. Yogyakarta: Ekonosia

Hirschman, E. (1983). *Religious Affiliation and Consumption Process: An Initial Paradigm*. Greenwich: JAI Press.

Imam Ghozali, (2005), *Aplikasi Analisis Multivariate dengan SPSS*, Semarang: Badan Penerbit UNDIP,

Irsyadi Zain dan Rahmat Akbar. (2020). *Bank dan Lembaga Keuangan Lainnya*. Yogyakarta: Deepublish Publisher

Jalaluddin Rakhmat (2003). *Psikologi Islam*. Jakarta: Raja Grafindo

Rahmat, Jalaludin, (1996), *Islam Aletrnatif*, Bandung: Mizan, 1996).

- Janis, Irving L.; Mann, Leon (1977). *Decision making: a psychological analysis of conflict, choice, and commitment*. New York: Free Press. ISBN 978-0029161609. OCLC 2542340.
- Johnson, B., Jang, S., Larson, D., & Li, S. (2001). Does Adolescent Religious Commitment Matter? A Reexamination Of The Effects Of Religiosity On Delinquency. *Journal of Research in Crime and Delinquency*, 38(1), 22-43.
- Kahmad, Dadang (2002). *Sosiologi Agama*. Bandung: Rosdakarya
- Khairina F. Hidayati. (2021). Pahami apa itu Bank Syariah dan Prinsipnya. <https://glints.com>. Diakses tanggal 15 Agustus 2021.
- Khraim, H. (2010) Measuring Religiosity in Consumer Research from Islamic Perspective. *International Journal of Marketing Studies*, 2(2), h.166-179
- Kim, S., David, S., and Zafer, B. (2004). The Influence of Religion on Attitudes Towards the Advertising of Controversial Products. *European Journal of Marketing*, 38(5/6), 537-555,
- Komaruddin, (1994), *Kamus Perbankan*, Jakarta : CV. Rajawali
- Kotler, Philip. (2010), *Manajemen Pemasaran*, Jakarta: PT. Erlangga
- Kotler, Philip. (2010). *Manajemen Pemasaran*. Edisi Milenium Satu. Indeks. Jakarta.
- Lada, S., Tanakinjal, G., & Amin, H. (2009). Predicting intention to choose Halal products using theory of reasoned action. *International Journal of Islamic and Middle Eastern Finance and Management*, 2(1), 66-76.
- Lestari, Alfi Mulikhah (2015), Pengaruh Religiusitas, Produk Bank, Kepercayaan, Pengetahuan, dan Pelayanan terhadap Preferensi menabung pada Perbankan Syariah (Studi Kasus Pada Mahasiswa FEB Universitas Brawijaya, *Jurnal Ilmiah FEB Universitas Brawijaya*
- Lia Aprilia, Monica Maulida Widiastuti, R.A Amanda Putri S.S, Serly Nufia Juliana, dan Adhitya Putri Pratiwi, (2020), Pengaruh Faktor Keagamaan Dan Kualitas Pelayanan Terhadap Keputusan Nasabah Menggunakan Jasa Bank Syariah, Prosiding Webinar Nasional, Vol. 1, No. 1, h. 75-90
- Ltifi, M., Hikkerova, L., Aliouat, B., & Gharbi, J. (2016). The determinants of the choice of Islamic banks in Tunisia. *International Journal of Bank Marketing*, 34(5), 710-730.

- Malhotra, Naresh. (2007), *Marketing Research : an applied orientation*, pearson education, inc., fifth edition. New Jearsey : USA
- Mann, Leon; Harmoni, Ros; Power, Colin (1991). "The GOFER course in decision making". In Baron, Jonathan; Brown, Rex V. (eds.). Teaching decision making to adolescents. *Hillsdale, NJ: Lawrence Erlbaum Associates*. pp. 61–78. ISBN 978-0805804973. OCLC 22507012
- Mariam Mourad Hussein Abou-Youssef, Wael Kortam, Ehab Abou-Aish, Noha El-Bassiouny, (2015). Effects of religiosity on consumer attitudes toward Islamic banking in Egypt, *International Journal of Bank Marketing*, Vol. 33 Issue, 6, hal.786-807
- Maski, Ghozali. (2010). Analisis Keputusan Nasabah Menabung: Pendekatan Komponen dan Model Logistik Studi pada Bank Syariah di Malang. *Journal of Indonesian Applied Economics*. Vol. 4 No.1
- McKnight, D. H Choudhury, and Kacmar, C (2002), Special Issue on Measuring eCommerce in Net-Enabled Organizations, Part 2 of 2: Developing and Validating Trust Measures for e-Commerce: An Integrative. *Typology Information Systems Research*. Vol. 13. Hlm. 334-359.
- Md-Taib, F., Ramayah, T., & Abdul-Razak, D. (2008). Factor influencing intention to use diminishing partnership home financing. *International Journal of Islamic and Middle Eastern Finance and Management*, 1(3), 235-248.
- Metwally, M. (1996). Attitudes of muslims towards Islamic banks in a dual-banking system. *American Journal of Islamic Finance*, 6, 11–17.
- Miniard Paul W, (2004), *Perilaku Konsumen*, Jakarta: PT. Binarupa Aksara
- Minto Waluyo, (2016), *Mudah Cepat Tepat Penggunaan Tools Amos Dalam Aplikasi (SEM)*. Penerbit : UPN "VETERAN" JATI.
- Mintz, Alex dan Junior, Karl DeRouen. (2012). The Rational Actor Model. Publisher: Cambridge University Press. <https://doi.org/10.1017/CBO9780511757761.004>. Hlm. 57-67
- Mokhlis, S. Consumer Religiosity and Shopping Behavior in Kuala Lumpur. (2007). *Malaysian Management Journal*, 11(1), 87- 101

- Mowen. J. C., dan Minor, M., (2002), *Perilaku Konsumen*, Jilid 1, Jakarta: Penerbit PT. Erlangga
- Muhammad Zuhirsyan dan Nurlinda. (2018). Pengaruh Religiusitas dan Persepsi Nasabah terhadap Keputusan Memilih Bank Syariah.. *Al-Amwal*, Volume 10, No. 1 Tahun 2018, h. 48-62
- Muhammad Zuhirsyan dan Nurlinda, (2018), Pengaruh Religiusitas dan Persepsi Nasabah terhadap Keputusan Memilih Bank Syariah, *Al-Amwal*, dalam Volume 10, No. 1, 48-62
- Muhlis. 2011. *Perilaku Menabung Di Perbankan Syariah Jawa Tengah. Disertasi. Program Studi Doktor Ilmu Ekonomi Universitas Diponegoro.*
- Mukhlis. 2019. *Perbankan Syariah Prospektif Cerah Di Kota Lhokseumawe. Aceh.* <https://antaranews.com>. diakses 27 Maret 2020
- Nashori, Fuad dan Rachmy Diana Mucharam. (2002), *Mengembangkan Kreativitas dalam Perspektif Psikologi Islam*. Yogyakarta: Menara Kudus
- Newaz, F. T., Fam, K.-S., & Sharma, R. R. (2016). Muslim religiosity and purchase intention of different categories of Islamic financial products. *Journal of Financial Services Marketing*, 21(2), 141–152. doi:10.1057/fsm.2016.7
- Nitisyia (2018) <http://www.politicalsciencenotes.com/articles/decision-making-theory-definition-nature-and-theories/743>
- Nizar Souden dan Marzouki Rani, (2015), Consumer attitudes and purchase intentions toward Islamic banks: the influence of religiosity, *International Journal of Bank Marketing*, Vol.33. No. 2. h. 143-161
- Nugroho, J. . (2003). *Perilaku Konsumen* (Edisi 1). Jakarta: Prenada media
- Nuritomo dan Budisantoso, Totok. (2014). *Bank dan Lembaga Keuangan Lainnya*. Jakarta: Salemba Empat
- Pantja Djati dan Ferrinadewi, (2004), Upaya Mencapai Loyalitas Konsumen dalam Perspektif Sumber Daya Manusia, *Jurnal Manajemen dan Kewirausahaan*, Vol. 6. No. 1
- Peppers, Don and Martha Rogers, (2004), *Managing Customer Relationships: A Strategic Framework*, New Jersey: John Wiley dan Sons, Inc.

- Pijanowski, John (2009). "The role of learning theory in building effective college ethics curricula". *Journal of College and Character*. 10 (3): 1–13. doi:10.2202/1940-1639.1088.
- Prajudi Atmosudirjo, (2005). *Beberapa Pandangan Umum tentang Pengambilan Keputusan*, Jakarta: Bumi Aksara
- Qosdan Dawami, (), Factors Influencing The Preference Of Customers Towards Islamic Banking: Evidence From Malaysia, *Journal of Islamic Economic Laws*, Vol. 3, No. 1 January 2020: 48-67
- Ramli. T., (2003), *Pendidikan Karakter*, Bandung : Angkasa.
- Relawu.(2007), Hubungan antara Religiusitas dengan Kecerdasan Emosi pada Remaja Beragama Islam. *Karya Ilmiah*, Fakultas Psikologi Universitas Indonesia Depok: Tidak Diterbitkan.
- Rizwan., et al (2014), Incorporating Attitude Towards Islamic Banking in an Integrated Service Quaity, Satisfaction, Trust and Loyalty Model, *International Journal of Accounting and Financial Reporting*, Vol. 4, No. 2, hal. 456-477
- Robbin dan Judge. (2015) *Perilaku Organisasi Edisi 16*. Jakarta. Salemba Empat.
- Rossarin, W. (2012). *Factors Influencing Repurchase Intetntion Of Thai Female Customer Toward Korean Cosmetics in Bangkok*. From : <http://gsbejournal.au.edu/Journals/June2012/Rossarin.pdf>.
- Salahuddin (1990), *Pengantar Psikologi Pendidikan*. Surabaya: Bina Ilmu.
- Santoso Singgih, (2002), *Statistik Parametrik*, Cetakan Ketiga, Jakarta: PT Gramedia Pustaka Utama
- Sarwono, S.W. (2009) *Psikologi Remaja*. Jakarta: Salemba Humanika
- Schiffman, L. G., & Kanuk, L. L. (2011). *Consumer Behavior (Fifth)*. New Jersey: Prentice-Hall Inc.
- Soengeng Wahyoedi, (2017), The Effect of Religiosity, Service Quality, and Trust on Customer Loyalty in Islamic Banking in Bogor Indonesia, *International Review of Management and Business Research*, Vol. 6, Issue 1, hal. 331-340

- Soegeng Wahyoedi, Hery Winoto.(2017). Pengaruh Religitas, Kualitas Layanan Dan Trust Terhadap Loyalitas Nasabah Bank Syariah Di Kota Bogor. *Jurnal Riset Ekonomi Dan Manajemen*, Vol. 12, No.2, 189-198
- Soesilowati, E. (2010). Behavior of Muslims in Consuming Halal foods: Case of Bantenese Muslim. *Paper presented at the Sharia Economics Research Day*, Widya Graha Lipi.
- Soetarno, (2004), Ragam Budaya Indonesia, Direktorat Pembinaan Pendidikan Tenaga Kependidikan dan Ketenagaan Perguruan Tinggi . Jakarta: Dirjen Dikti - Depdiknas,
- Souiden, N., & Rani, M. (2015). Consumer attitudes and purchase intentions toward Islamic banks: the influence of religiosity. *International Journal of Bank Marketing*, 33(2), 143-161.
- Souiden,Nizar dan Rani M. (2015), "Consumer attitudes and purchase intentions toward Islamic banks: the influence of religiosity", *International Journal of Bank Marketing*, Vol. 33 No. 2, pp. 143-161. <https://doi.org/10.1108/IJBM-10-2013-0115>
- Sri Wahyuningsih, (2020). Pengaruh Religiusitas Dan Pengetahuan Produk Terhadap Keputusan Pembelian Produk Halal Dengan Kepercayaan Sebagai Variabel Intervening (Studi Kasus Pada Produk HNI-HPAI), Vol. 9.No. 1,
- Sugiyono (2009). *Metode Penelitian Bisnis*. Bandung : Alfabeta, 2009
- Suliyanto, (2004), *Ekonometrika Terapan: Teori dan Aplikasi dengan SPSS*. Yogyakarta: ANDI,
- Sunaryo1 , Soegeng Wahyoedi2 , Achmad Sudiro3 , Sudjatno. (2020),The Effect of Religiosity on the Improvement of Customer Loyalty Towards Islamic Banks, *International Journal of Economics and Business Administration*. Volume 8, Issue 4
- Suparlan, Prasudi (2004), Masyarakat Majemuk, Masyarakat Multikultural, dan Minoritas: Memperjuangkan hak minoritas. *Makalah. Workshop Yayasan Interseksi, Hak-hak Minoritas dalam Landscape Multikultural, Mungkinkah di Indonesia?*
- Sutan Remy Sjahdeini. (2007). *Perbankan Islam*, Jakarta: PT Pustaka Utama Grafiti

- Syahridlo (2004). Pengaruh Prestasi Pelajaran Agama Terhadap Sikap Keagamaan Siswa Madrasah Aliyah Negeri Bantul. *Tesis Magister Psikologi UNY*
- Tabachnick, B. G., dan Fidell, L.S. (2007), *Using Multivariate Statistics*. Ed.5. Boston: Perason
- Terpstra, V., & Sarathy, R. (2000). *Pemasaran Internasional* (8 ed.). Fort Worth, FL: The Dryden Press.
- Thy Widiyono (2006), *Aspek Hukum Operasional Transaksi Produk Perbankan Di Indonesia*, Bogor: Ghalia Indonesia
- Turner, Brian S, (2006), *Agama dan Teori Sosial Rangka- Pikir Sosiologi Dalam Membaca Eksistensi Tuhan Diantara Gelegar Ideologi-ideologi Kontemporer*, Yogyakarta: IRCiSoD., 2006). hlm. 62
- Undang-Undang No. 10 Tahun 1998 tentang Perubahan Atas Undang-Undang No. 7 Tahun 1992 tentang Perbankan
Undang-undang Nomor 21 tahun 2008 tentang Perbankan Syariah
- Utami, Fajria Anindya. (2020). *Apa itu Bank Syariah?*, www.wartaekonomi.co.id. Diakses 16 Agustus 2020
- Utomo, Toni Prasetyo dan Burhan, M. Umar. Analisis Faktor-Faktor Yang Mempengaruhi Keputusan Nasabah dalam Memilih Jasa Perbankan Syariah (Studi Pada Bank Syariah Mandiri, Kantor Cabang Malang). *Jurnal Ilmu Manajemen*. No. 2, Vol. 2.
- Vico Putri Nilam Sari, (2020), Pengaruh kepercayaan dan Sistem Bagi Hasil Terhadap Keputusan Pemilihan Produk Deposito Mudharabah Dengan Pemoderasi Religiusitas Di Bank Jatim Syariah Malang, *Tesis*, Univesitas Muhammadiyah Malang
- Vitell, S., & Paolillo, J. (2003). Consumer ethics: The role of religiosity. *Journal of Business Ethics*, 46(2), 151–162
- W. Houston Clark, (1985), *An Introduction to The Psychology of Religion: an Introduction to Religious Experience and Behaviour*, New York: The McMillan Company.
- Wandemberg. JC. (2017). Organizational Design Principles (Part 2). <https://jcwandemberg.medium.com>. Diakses 01 Agustus 2021

Widhiarso, Wahyu. (2010). *Pengembangan Skala Psikologi*. Draft. Universitas Gajah Mada: Tidak diterbitkan.

Widiyanta, Ari. 2005. Sikap Terhadap Lingkungan Dan Religiusitas. *Psikologia* Volume I, No. 2, 2005

www.ojk.go.id/id/kanal/syariah/tentang-syariah/Pages/Sejarah-Perbankan-Syariah.aspx

www.syariahbukopin.co.id/id/syariah/bank-syariah

Yogaswara Achmad Tanuwijaya dan Imam Murtono Soenhadji (2009), Pengaruh Kemampuan Karyawan, Kejelasan Aturan, Kesempatan Berkinerja dan Penghargaan Perusahaan Terhadap Kinerja Karyawan. (*Paper*, 2009)

Youssef, M., Kortam, W., Aish, E., & El-Bassiouny, N. (2011). Measuring Islamic-driven buyer behavioral implications: A proposed market-minded religiosity scale. *Journal of American Science*, 7(8).

Yusman Alim Djasmin Maku. *Penerapan Prinsip-prinsip tentang perbankan syariah hubungannya dengan otoritas jasa keuangan*. *Lex Crimen* Vol. VI/No. 1/Jan-Feb/2017

Yusuf Shofie, (2003), *Perlindungan Konsumen dan Instrumen-Instrumen Hukumnya*, Bandung; Citra Aditya Bakti

Zainuddin Ali, (2010). *Hukum Perbankan Syariah*, Jakarta: Sinar Grafika



Lampiran 1. Kuesioner Penelitian

KUESIONER PENELITIAN

**PENGARUH RELIGIUSITAS TERHADAP KEPUTUSAN NASABAH
DALAM MEMILIH BANK SYARIAH DENGAN SIKAP DAN
KEPERCAYAAN SEBAGAI VARIABEL INTERVENING
DI KOTA LHOKSEUMAWE**

Assalamu'alaikum. Wr. Wb.

Sebelumnya saya mengucapkan terima kasih atas kesediaan Bapak/Ibu/Saudara untuk mengisi kuesioner berikut ini. Saat ini saya sedang melakukan penelitian bidang manajemen sumber daya manusia pada Program Doktor Ekonomi Syariah Universitas Islam Negeri Sumatera Utara (UINSU). Dalam rangka pengumpulan data untuk memenuhi syarat dalam menyelesaikan disertasi saya pada Program Doktor Ekonomi Syariah Universitas Islam Negeri Sumatera Utara. Saya memohon kesediaan dan bantuan Bapak/Ibu/Saudara agar dapat meluangkan waktu untuk mengisi kuesioner ini.

Hasil kuesioner ini sepenuhnya akan digunakan untuk kepentingan akademik dan tidak berpengaruh pada penilaian kinerja kerja di perusahaan Bapak/Ibu. Saya berharap Bapak/Ibu menjawab dengan selengkap mungkin, kejujuran dan kesungguhan Bapak/Ibu/Saudara dalam mengisi kuesioner ini akan sangat berarti dan saya hargai.

Atas kesediaan serta kerjasama Bapak/ibu/Saudara, saya ucapkan terima kasih.

Hormat Saya,



UIN
SUMATERA UTARA
MEDAN

Anwar Puteh

PETUNJUK PENGISIAN KUESIONER

Dalam menjawab pertanyaan pada kuesioner ini, cukup dengan membubuhkan tanda “√” (centang) di tengah – tengah kotak yang disediakan. Jawaban tersebut dianggap yang paling sesuai dengan pendapat Anda.

Keterangan : SS: Sangat setuju S: Setuju N: Netral TS: Tidak setuju
STS: Sangat tidak setuju

A. Identitas Responden

Usia	<input type="checkbox"/> 17 - 25 Tahun <input type="checkbox"/> 26 - 35 Tahun <input type="checkbox"/> 36 - 45 Tahun <input type="checkbox"/> 45 - Keatas
Jenis Kelamin	<input type="checkbox"/> Laki-laki <input type="checkbox"/> Perempuan
Pendidikan	<input type="checkbox"/> SMA/Sederajat <input type="checkbox"/> Diploma <input type="checkbox"/> Sarjana <input type="checkbox"/> Magister
Pekerjaan	<input type="checkbox"/> Wiraswasta <input type="checkbox"/> PNS <input type="checkbox"/> TNI/Polri <input type="checkbox"/> Pegawai Swasta <input type="checkbox"/> Lain-lain
Status	<input type="checkbox"/> Kawin <input type="checkbox"/> Belum Kawin <input type="checkbox"/> Duda/Janda
Menabung Pada	<input type="checkbox"/> Bank Muamalat Indonesia <input type="checkbox"/> BNI Syariah <input type="checkbox"/> BRI Syariah <input type="checkbox"/> Bank Syariah Mandiri <input type="checkbox"/> CIMB Syariah

	() Bank Aceh
--	---------------

B. Kuesioner Variabel Penelitian

No	Butir Pernyataan	SKOR				
		STS	TS	N	S	SS
I.	Religiusitas					
1	Saya yakin kegiatan operasional Bank Syariah sesuai hukum iskam.					
2	Melakukan kegiatan pada Bank Syariah merupakan pengamalan keagamaan bagi saya.					
3	Saya sebagai muslim sangat menghayati dan menikmati semua produk Bank Syariah					
4	Saya memiliki pengetahuan yang cukup tentang kegiatan Bank Syariah					
5	Saya memilih bank syariah terbebas dari masalah riba					
II.	Sikap	STS	TS	N	S	SS
1	Saya yakin produk bank syariah terhindar masalah riba					
2	Saya memilih bank Syariah karena budaya yang ada di daerah dan keluarga					
3	Saya senang dengan berbagai produk Bank Syariah					
4	Saya selalu mencari informasi tentang produk bank syariah					
5	Saya dengan senang hati mempromosi Bank Syariah kepada masyarakat					
III.	Kepercayaan	STS	TS	N	S	SS
1	Pegawai Bank Syariah memiliki integritas dan kejujuran					
2	Pegawai Bank Syariah memiliki kompetensi dan pengetahuan dalam menjalankan kegiatan bank					
3	Pegawai Bank Syariah memiliki selalu menjaga hubungan baik dengan nasabah					
4	Nasabah sangat loyal terhadap Bank Syariah					
5	Bank syariah terbuka terhadap nasabah dalam melayani kegiatan operasional					
IV	Keputusan Nasabah	STS	TS	N	S	SS
1	Produk Bank Syariah yang bervariasi menjadi pilihan dalam bertransaksi pada bank tersebut					
2	Metode pembayaran transaksi tidak mempersulit nasabah					
3	Bank Syariah saat ini mudah dijangkau nasabah					
4	Pelayananyang diberikan cukup menyenangkan nasabah					

5	Pembiayaan pada Bank Syariah menjadi andalan bagi masyarakat Kota Lhokseumawe karena terhindar dari riba					
6	Seluruh Bank Syariah di Kota Lhokseumawe telah menggunakan <i>online banking system</i>					

TERIMAKASIH ATAS PARTISIPASINYA



Lampiran 2. Data Penelitian

No.	S1	S2	S3	S4	S5	R1	R2	R3	R4	R5	KN1	KN2	KN3	KN4	KN5	KN6	K1	K2	K3	K4	K5
1	4	4	4	4	2	2	1	3	1	2	3	1	3	3	3	2	4	4	2	2	3
2	4	4	4	4	4	2	2	3	3	4	4	4	3	2	4	4	4	2	3	3	3
3	2	2	2	2	2	3	1	2	3	4	4	4	2	4	3	4	5	5	2	4	3
4	3	3	3	3	4	3	4	4	4	4	4	4	2	4	2	2	1	1	3	1	1
5	3	3	3	3	5	3	4	2	2	4	4	4	2	3	4	4	5	5	5	5	5
6	3	3	3	3	4	3	4	3	4	5	4	5	3	5	5	5	2	2	2	2	2
7	2	2	2	2	2	3	4	1	1	1	2	4	1	3	4	2	4	2	3	3	2
8	2	2	2	2	4	2	3	1	1	1	2	4	1	4	2	3	5	3	4	2	4
9	3	3	3	3	2	2	3	2	3	1	3	4	2	4	4	3	2	2	2	3	2
10	2	2	2	2	4	4	4	4	4	3	3	4	4	4	4	3	5	5	4	4	4
11	3	3	3	3	4	2	1	2	3	1	1	5	2	5	3	3	4	4	3	3	2
12	3	3	3	3	3	3	4	3	4	4	2	4	3	4	4	3	5	5	5	5	5
13	2	3	3	2	3	2	1	2	3	1	2	2	2	4	1	2	2	2	2	2	2
14	5	1	5	2	3	2	1	1	3	1	3	4	1	3	3	4	4	2	3	3	2
15	2	3	2	1	3	4	4	4	5	2	4	4	4	4	2	4	5	5	4	4	4
16	3	4	4	5	4	2	1	2	2	1	2	4	2	4	3	1	4	1	3	3	3
17	3	4	1	5	2	3	1	1	3	1	3	4	1	4	4	3	4	4	3	3	2
18	3	4	1	5	4	4	3	3	4	5	1	2	3	2	2	2	5	5	4	4	2
19	3	3	3	5	2	1	1	2	2	2	4	5	2	5	5	1	1	1	1	2	2
20	1	1	1	2	4	5	4	4	4	3	1	2	4	3	2	2	1	1	1	2	1
21	2	2	2	2	5	2	1	1	3	2	1	1	1	4	3	1	4	5	4	4	5
22	3	3	3	4	4	3	2	3	2	4	3	4	3	4	4	1	4	4	3	3	3
23	4	4	4	3	4	4	3	3	3	4	2	4	3	3	4	2	4	3	3	3	3
24	1	1	1	1	3	4	4	4	3	3	2	2	4	3	2	1	2	3	2	3	3
25	1	1	1	1	1	1	2	2	1	2	3	2	2	4	2	2	1	1	1	1	1
26	4	4	4	1	2	2	1	1	1	2	3	2	1	2	2	1	5	5	4	4	5
27	4	4	4	5	3	1	2	1	1	1	4	5	1	5	5	1	2	4	5	3	4
28	1	1	1	2	3	2	1	2	2	2	1	1	2	2	1	2	3	3	2	3	3
29	3	3	3	1	1	4	4	4	4	4	2	3	4	3	3	1	5	4	3	4	5
30	3	3	3	3	3	2	1	2	2	2	2	4	2	4	4	3	4	3	2	2	4
31	1	1	1	2	2	1	2	1	2	2	2	3	1	3	3	3	2	2	1	2	1
32	1	1	1	2	2	1	2	1	1	1	3	4	1	3	4	3	2	1	5	2	1
33	3	2	3	2	4	5	4	4	4	4	3	4	4	5	4	3	4	3	2	4	4
34	3	3	3	2	4	1	2	2	2	1	1	1	2	1	1	1	1	1	2	1	1
35	2	3	3	2	3	2	1	2	1	1	4	5	2	5	5	5	4	3	3	3	1
36	3	3	1	2	2	4	3	3	4	4	3	2	3	2	2	3	5	4	2	3	3
37	5	5	4	5	5	5	5	5	5	5	3	1	4	4	1	3	3	2	5	3	4
38	4	5	4	5	5	1	1	2	2	2	3	5	2	4	5	3	3	3	2	5	5
39	4	5	2	5	5	4	4	4	4	4	4	3	1	4	5	1	2	2	5	2	2
40	2	3	1	3	3	5	5	5	5	5	3	2	5	5	4	4	5	2	2	5	5
41	3	5	2	5	5	1	2	1	1	1	5	4	1	5	5	4	4	2	2	4	4
42	2	1	3	1	1	4	1	2	1	1	3	2	2	4	4	4	4	5	5	4	4
43	3	2	4	2	2	4	1	2	2	2	4	2	2	4	4	4	2	1	1	2	1
44	3	2	4	2	2	4	1	2	1	1	3	2	2	4	4	4	2	5	5	1	1
45	2	3	4	3	3	2	2	1	1	1	4	4	1	4	4	4	4	4	4	5	4
46	2	3	5	3	3	4	1	3	1	4	3	4	3	4	4	4	4	2	2	4	4
47	3	5	1	5	5	4	3	4	4	4	3	4	4	4	4	4	1	5	5	2	2
48	2	2	1	2	2	2	4	4	4	4	3	5	4	3	3	3	5	5	2	3	3
49	3	3	5	3	3	4	5	5	5	5	2	4	5	2	2	2	5	2	2	5	5
50	2	2	1	2	2	2	1	4	3	2	1	3	4	1	1	1	2	2	2	2	2

51	3	4	1	4	4	5	4	5	4	5	3	5	5	3	3	3	4	4	4	5	4
52	4	3	3	4	3	3	2	1	2	2	3	5	1	2	3	3	2	2	2	1	2
53	3	4	2	2	1	4	1	1	4	5	3	5	1	3	3	3	4	4	4	5	5
54	2	3	3	3	2	1	4	2	4	2	3	5	2	3	3	3	3	5	5	4	5
55	2	2	2	2	2	2	1	1	2	2	2	2	1	1	2	2	1	2	2	2	2
56	1	1	1	1	1	5	2	1	1	1	4	5	1	3	3	3	2	4	4	3	2
57	3	3	3	3	3	5	4	4	4	4	3	5	4	3	3	3	5	5	5	5	5
58	2	2	2	2	2	5	2	1	2	1	1	3	1	1	1	1	2	2	2	2	2
59	5	5	5	5	5	5	1	1	1	5	4	5	1	3	3	3	2	2	2	2	1
60	3	3	5	3	3	2	1	3	3	5	2	2	3	1	2	2	1	1	1	2	2
61	4	4	4	4	4	5	4	5	5	5	4	1	5	3	3	3	3	4	4	3	5
62	1	1	1	1	1	1	2	1	2	2	3	1	1	3	3	3	3	5	5	4	5
63	5	5	5	5	5	1	3	5	4	5	3	4	5	3	3	3	3	5	5	5	5
64	3	3	3	3	3	4	5	4	4	4	4	3	4	1	3	3	3	4	4	3	4
65	4	4	4	4	4	4	1	2	1	1	5	5	2	5	5	5	3	4	4	5	2
66	4	4	4	4	4	5	4	1	4	4	4	4	1	4	4	4	1	2	2	2	3
67	4	4	4	4	4	4	1	2	1	1	4	4	2	4	4	4	3	4	4	5	4
68	5	5	5	5	5	2	2	1	3	1	4	4	1	1	3	3	3	4	4	4	5
69	5	5	5	5	5	2	1	4	2	2	4	3	4	3	4	3	3	5	5	3	5
70	3	1	3	4	2	3	2	5	1	2	5	5	5	5	4	5	3	4	4	5	4
71	5	1	1	1	1	4	3	4	3	5	1	1	4	1	1	1	5	5	5	5	5
72	5	5	1	4	2	4	4	5	5	5	4	3	5	4	3	3	3	5	5	4	2
73	3	3	3	3	3	2	1	1	2	2	3	5	1	2	3	2	2	2	2	1	1
74	3	2	2	1	1	5	3	2	5	5	2	2	2	3	3	3	4	5	5	5	5
75	3	5	3	2	4	3	1	1	2	5	3	4	1	3	1	2	3	5	5	5	4
76	5	5	5	5	5	4	4	4	4	5	2	2	4	2	2	2	4	5	5	4	5
77	4	4	4	4	4	4	4	1	4	5	4	5	1	4	4	5	4	4	4	4	5
78	5	5	5	5	5	4	4	4	4	5	1	3	3	5	3	3	3	4	4	4	5
79	5	5	5	5	5	5	5	5	5	5	3	4	4	3	3	4	4	5	5	5	5
80	4	4	4	4	4	1	4	4	4	4	4	5	4	4	4	5	3	4	4	4	5
81	5	5	5	5	5	1	2	3	4	5	3	4	4	3	2	4	3	4	4	5	5
82	4	4	4	4	4	5	5	4	4	4	4	5	4	5	4	5	3	3	5	4	4
83	2	2	2	2	2	2	1	1	1	4	3	4	4	4	3	4	1	1	2	2	1
84	1	1	1	1	1	2	1	2	1	4	3	4	4	4	3	4	4	5	5	5	5
85	4	4	4	4	4	5	5	4	4	4	5	5	5	5	4	5	5	5	5	5	5
86	4	4	4	4	4	2	1	2	1	1	4	4	4	4	4	4	3	4	4	4	5
87	3	3	1	3	3	4	4	5	4	4	1	1	1	1	1	1	2	1	4	3	4
88	1	1	1	1	1	5	1	1	2	2	3	3	3	3	3	3	3	3	4	4	4
89	5	5	5	5	5	4	3	3	4	4	4	4	4	4	4	4	3	4	4	4	2
90	4	2	2	2	1	3	4	5	4	4	1	1	3	1	1	1	1	1	1	1	1
91	5	5	5	5	5	1	3	2	3	2	4	4	4	4	4	4	4	5	5	5	5
92	4	1	1	1	2	2	5	4	4	5	1	1	1	1	1	1	4	4	5	5	5
93	2	1	1	1	2	3	4	4	3	5	5	4	2	4	4	1	4	4	4	4	4
94	5	4	2	2	4	2	3	2	2	5	3	3	2	4	4	2	2	1	2	2	2
95	4	2	2	3	1	3	3	5	3	3	3	5	2	5	4	2	4	3	4	4	5
96	5	4	5	5	4	1	1	2	1	1	4	5	1	5	5	1	4	5	5	5	5
97	4	5	4	3	4	2	2	5	2	4	5	5	1	3	4	2	2	2	3	3	3
98	4	4	3	3	3	3	3	3	3	4	4	4	5	5	4	4	1	3	4	4	5
99	4	3	1	2	4	4	4	4	4	4	5	5	1	5	5	1	3	4	4	4	4
100	4	2	2	3	4	2	2	1	1	1	1	5	5	1	1	2	2	2	4	4	5

101	1	1	2	5	3	3	3	4	3	3	1	2	2	1	1	1	3	5	3	4	5
102	2	4	2	3	3	2	2	1	2	1	2	1	2	3	3	1	1	1	2	1	1
103	5	5	5	5	5	1	1	1	2	2	5	2	2	4	5	1	1	1	1	1	1
104	5	5	5	5	5	4	4	4	4	4	3	2	2	4	4	1	4	4	4	5	5
105	4	4	4	4	2	1	1	1	2	2	1	5	5	1	2	2	4	4	5	4	4
106	5	5	5	5	4	4	5	5	5	5	4	2	5	4	1	1	3	5	5	5	5
107	4	4	4	4	4	2	2	1	1	1	4	5	5	5	4	2	5	1	4	4	5
108	2	2	2	2	4	1	1	1	1	2	4	2	4	2	4	1	2	1	3	4	4
109	4	4	4	4	5	5	5	5	5	4	5	2	5	5	1	2	4	1	3	4	4
110	4	4	4	4	5	5	5	5	5	5	4	2	5	5	4	1	4	5	5	5	5
111	4	4	3	4	5	3	4	5	5	5	1	2	3	2	2	1	4	2	2	2	5
112	5	5	5	5	5	5	5	4	5	5	4	5	4	4	4	1	5	4	2	2	5
113	3	3	3	3	3	1	1	1	2	2	4	5	5	5	1	2	1	2	1	1	2
114	4	4	2	4	5	4	4	3	4	4	5	2	4	4	5	1	4	5	5	5	5
115	4	4	2	4	5	4	4	2	4	4	5	4	5	4	4	4	4	1	1	1	1
116	5	5	4	5	4	4	4	5	4	4	4	4	5	4	1	1	2	1	2	1	2
117	4	4	2	4	5	1	1	3	1	1	4	3	4	5	5	5	4	1	2	2	3
118	5	5	2	3	5	4	3	4	4	4	2	2	5	1	3	3	1	1	1	2	2
119	5	5	3	2	1	1	2	1	1	5	5	5	5	5	5	5	4	1	4	4	5
120	1	1	1	2	1	2	2	2	1	1	2	4	2	4	4	4	1	1	2	1	1
121	5	4	5	3	4	5	5	5	5	5	1	4	2	1	1	1	1	2	2	2	2
122	1	5	1	5	1	2	3	2	2	4	4	4	4	2	4	4	4	2	4	4	5
123	4	2	4	1	5	2	4	4	2	4	2	4	4	1	2	2	4	2	4	2	4
124	4	4	5	5	4	2	3	3	2	4	2	5	4	3	4	3	4	5	5	4	1
125	5	4	5	4	4	4	1	4	3	2	4	3	1	4	4	4	4	3	4	3	4
126	4	4	3	2	4	1	2	1	2	3	5	2	4	4	4	5	4	4	4	5	4
127	1	2	5	4	4	1	2	3	3	4	3	4	5	3	3	3	4	4	4	4	3
128	2	4	3	5	2	4	4	4	5	5	4	5	5	5	5	5	4	4	4	4	5
129	4	2	5	5	4	5	5	5	5	5	5	5	5	5	5	5	2	2	4	4	2
130	1	4	3	3	4	5	5	5	5	5	4	2	4	2	4	4	4	2	4	4	1
131	2	4	4	5	5	5	4	4	4	4	1	1	1	2	2	1	1	2	2	2	2
132	4	2	2	2	5	2	4	4	4	4	5	5	4	4	5	5	4	3	3	4	2
133	2	4	5	1	5	5	5	5	5	5	4	4	4	3	4	4	4	2	4	3	4
134	5	5	5	3	5	1	1	2	1	1	4	3	4	3	3	4	4	4	4	3	5
135	2	2	5	5	2	3	1	3	3	5	2	4	4	2	1	2	2	2	2	2	5
136	5	5	5	1	5	4	4	4	5	5	4	4	5	4	3	4	5	5	5	4	5
137	1	2	2	3	2	4	5	5	5	5	4	2	2	2	2	2	1	1	2	2	2
138	3	1	3	2	3	3	3	1	2	5	2	4	4	3	4	4	5	3	4	4	4
139	5	1	1	5	5	3	2	2	1	1	5	5	5	4	1	4	4	4	4	4	3
140	4	5	5	5	5	1	1	1	1	1	2	4	5	3	5	3	4	3	4	4	5
141	5	5	5	5	5	2	4	3	4	4	2	5	5	3	5	2	5	4	5	5	5
142	4	1	1	3	1	1	1	1	1	1	4	4	4	2	2	3	4	2	3	4	2
143	2	5	4	5	5	2	3	4	4	4	4	4	2	4	3	4	4	4	4	4	4
144	1	1	1	1	1	1	1	2	2	2	3	4	4	3	4	4	1	1	1	2	2
145	4	2	2	2	5	4	2	1	1	2	4	5	2	3	4	5	4	3	5	5	5
146	1	5	3	2	4	4	1	2	1	1	5	4	4	3	3	4	4	4	4	4	5
147	5	2	3	2	5	4	3	4	4	4	4	5	4	5	4	5	4	4	4	4	1
148	4	1	5	4	2	1	2	2	2	2	4	2	3	2	2	2	4	5	4	4	4
149	5	4	4	4	1	4	3	1	2	5	2	5	5	3	4	5	4	4	4	4	5
150	4	2	4	4	5	2	1	4	5	5	5	5	4	4	5	5	5	3	4	3	4

Lampiran 3. Uji CFA

Variabel Religiusitas

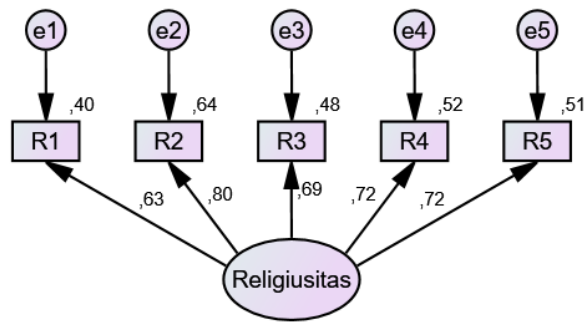

Regression Weights: (Group number 1 - Default model)

	Estimate	S.E.	C.R.	P	Label
R1 <--- Religiusitas	1,000				
R2 <--- Religiusitas	1,306	,151	8,639	***	
R3 <--- Religiusitas	1,152	,147	7,833	***	
R4 <--- Religiusitas	1,152	,142	8,117	***	
R5 <--- Religiusitas	1,158	,144	8,050	***	

Standardized Regression Weights: (Group number 1 - Default model)

	Estimate
R1 <--- Religiusitas	,635
R2 <--- Religiusitas	,800
R3 <--- Religiusitas	,689
R4 <--- Religiusitas	,724
R5 <--- Religiusitas	,716

Variances: (Group number 1 - Default model)

	Estimate	S.E.	C.R.	P	Label
Religiusitas	,757	,163	4,631	***	
e1	1,122	,129	8,726	***	
e2	,728	,110	6,640	***	
e3	1,110	,134	8,286	***	
e4	,912	,115	7,906	***	
e5	,966	,121	8,006	***	

Variabel Sikap

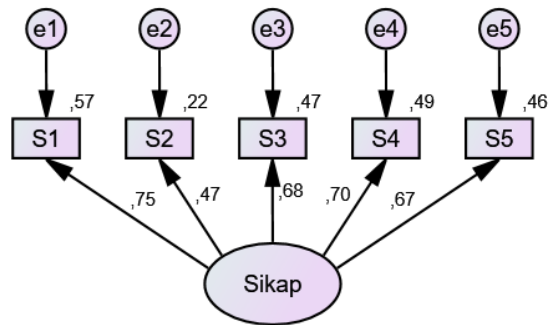

Regression Weights: (Group number 1 - Default model)

	Estimate	S.E.	C.R.	P	Label
S1 <--- Sikap	1,000				
S2 <--- Sikap	,673	,114	5,924	***	
S3 <--- Sikap	,886	,105	8,430	***	
S4 <--- Sikap	,956	,112	8,569	***	
S5 <--- Sikap	,932	,112	8,338	***	

Standardized Regression Weights: (Group number 1 - Default model)

	Estimate
S1 <--- Sikap	,755
S2 <--- Sikap	,470
S3 <--- Sikap	,684
S4 <--- Sikap	,697
S5 <--- Sikap	,675

Variances: (Group number 1 - Default model)

	Estimate	S.E.	C.R.	P	Label
Sikap	,897	,160	5,587	***	
e1	,677	,100	6,750	***	
e2	1,433	,154	9,306	***	
e3	,803	,102	7,847	***	
e4	,866	,113	7,670	***	
e5	,932	,117	7,951	***	

Variabel Sikap Buang Indikator

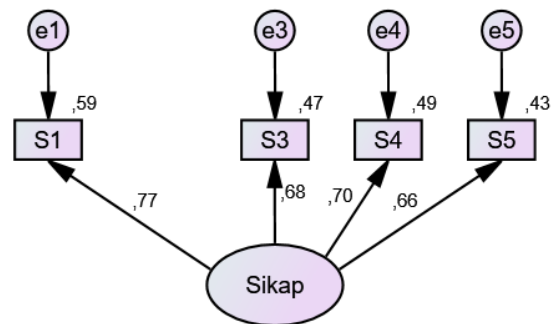

Regression Weights: (Group number 1 - Default model)

	Estimate	S.E.	C.R.	P	Label
S1 <--- Sikap	1,000				
S3 <--- Sikap	,869	,105	8,304	***	
S4 <--- Sikap	,937	,111	8,427	***	
S5 <--- Sikap	,893	,111	8,074	***	

Standardized Regression Weights: (Group number 1 - Default model)

	Estimate
S1 <--- Sikap	,769
S3 <--- Sikap	,683
S4 <--- Sikap	,697
S5 <--- Sikap	,659

Variances: (Group number 1 - Default model)

	Estimate	S.E.	C.R.	P	Label
Sikap	,931	,165	5,629	***	
e1	,643	,104	6,190	***	
e3	,805	,105	7,701	***	
e4	,868	,116	7,510	***	
e5	,967	,121	7,986	***	

Variabel Kepercayaan

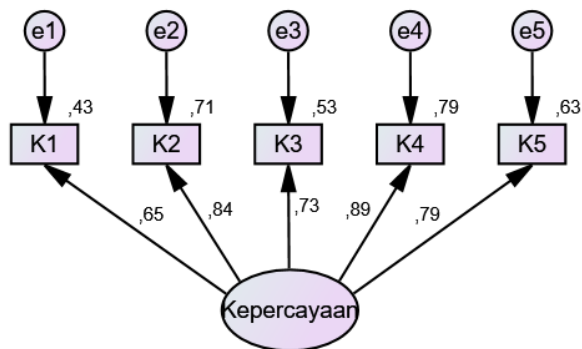

Regression Weights: (Group number 1 - Default model)

	Estimate	S.E.	C.R.	P	Label
K1 <--- Kepercayaan	1,000				
K2 <--- Kepercayaan	1,335	,133	10,040	***	
K3 <--- Kepercayaan	1,125	,126	8,953	***	
K4 <--- Kepercayaan	1,388	,134	10,384	***	
K5 <--- Kepercayaan	1,348	,141	9,578	***	

Standardized Regression Weights: (Group number 1 - Default model)

	Estimate
K1 <--- Kepercayaan	,655
K2 <--- Kepercayaan	,845
K3 <--- Kepercayaan	,730
K4 <--- Kepercayaan	,889
K5 <--- Kepercayaan	,794

Variances: (Group number 1 - Default model)

	Estimate	S.E.	C.R.	P	Label
Kepercayaan	,821	,164	5,003	***	
e1	1,093	,119	9,200	***	
e2	,588	,081	7,278	***	
e3	,909	,103	8,784	***	
e4	,420	,070	5,967	***	
e5	,874	,107	8,169	***	

Variabel Keputusan Nasabah

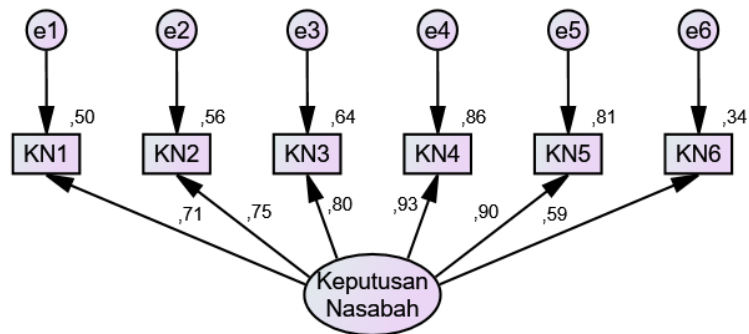

Regression Weights: (Group number 1 - Default model)

	Estimate	S.E.	C.R.	P	Label
KN1 <--- Keputusan_Nasabah	1,000				
KN2 <--- Keputusan_Nasabah	,840	,061	13,765	***	
KN3 <--- Keputusan_Nasabah	,910	,058	15,621	***	
KN4 <--- Keputusan_Nasabah	1,177	,054	21,676	***	
KN5 <--- Keputusan_Nasabah	1,000				
KN6 <--- Keputusan_Nasabah	,673	,072	9,401	***	

Standardized Regression Weights: (Group number 1 - Default model)

	Estimate
KN1 <--- Keputusan_Nasabah	,711
KN2 <--- Keputusan_Nasabah	,751
KN3 <--- Keputusan_Nasabah	,803
KN4 <--- Keputusan_Nasabah	,929
KN5 <--- Keputusan_Nasabah	,899
KN6 <--- Keputusan_Nasabah	,587

Variances: (Group number 1 - Default model)

	Estimate	S.E.	C.R.	P	Label
Keputusan_Nasabah	1,302	,156	8,356	***	
e1	1,277	,137	9,326	***	
e2	,709	,078	9,100	***	
e3	,595	,068	8,735	***	
e4	,288	,052	5,593	***	
e5	,309	,044	6,967	***	
e6	1,122	,117	9,625	***	

Variabel Keputusan Nasabah Buang Indikator

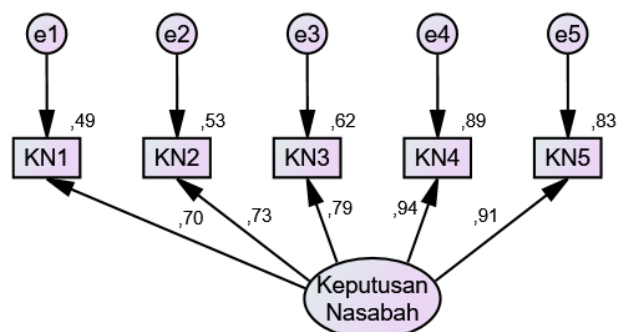

Regression Weights: (Group number 1 - Default model)

	Estimate	S.E.	C.R.	P	Label
KN1 <--- Keputusan_Nasabah	1,000				
KN2 <--- Keputusan_Nasabah	,800	,061	13,170	***	
KN3 <--- Keputusan_Nasabah	,880	,057	15,313	***	
KN4 <--- Keputusan_Nasabah	1,178	,051	23,279	***	
KN5 <--- Keputusan_Nasabah	1,000				

Standardized Regression Weights: (Group number 1 - Default model)

	Estimate
KN1 <--- Keputusan_Nasabah	,703
KN2 <--- Keputusan_Nasabah	,726
KN3 <--- Keputusan_Nasabah	,787
KN4 <--- Keputusan_Nasabah	,943
KN5 <--- Keputusan_Nasabah	,913

Variances: (Group number 1 - Default model)

	Estimate	S.E.	C.R.	P	Label
Keputusan_Nasabah	1,341	,158	8,498	***	
e1	1,375	,146	9,409	***	
e2	,769	,083	9,292	***	
e3	,637	,071	8,962	***	
e4	,230	,049	4,722	***	
e5	,269	,041	6,497	***	

Lampiran 4. Model Stuktural

Full Model Sebelum Modifikasi

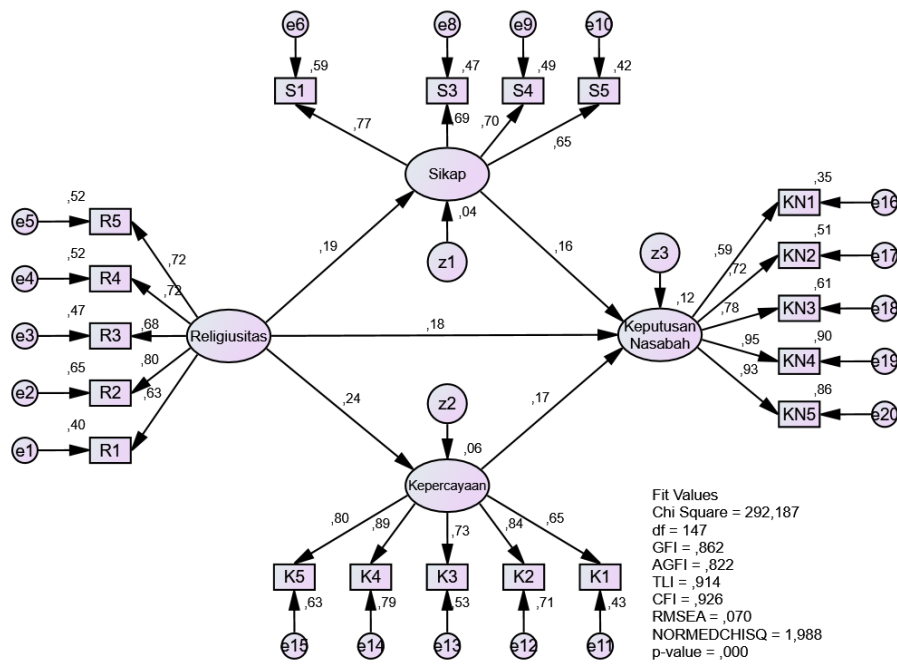

Regression Weights: (Group number 1 - Default model)

		Estimate	S.E.	C.R.	P	Label
Sikap	<--- Religiusitas	,212	,097	2,175	,030	
Kepercayaan	<--- Religiusitas	,247	,088	2,813	,005	
Keputusan_Nasabah	<--- Sikap	,138	,070	1,965	,049	
Keputusan_Nasabah	<--- Religiusitas	,177	,080	2,211	,027	
Keputusan_Nasabah	<--- Kepercayaan	,157	,072	2,169	,030	
R1	<--- Religiusitas	1,000				
R2	<--- Religiusitas	1,313	,151	8,701	***	
R3	<--- Religiusitas	1,144	,146	7,815	***	
R4	<--- Religiusitas	1,149	,141	8,124	***	
R5	<--- Religiusitas	1,163	,144	8,101	***	
S1	<--- Sikap	1,000				
S3	<--- Sikap	,874	,104	8,423	***	
S4	<--- Sikap	,935	,110	8,500	***	
S5	<--- Sikap	,880	,109	8,043	***	
KN1	<--- Keputusan_Nasabah	1,000				
KN2	<--- Keputusan_Nasabah	1,097	,135	8,127	***	
KN3	<--- Keputusan_Nasabah	1,214	,141	8,608	***	
KN4	<--- Keputusan_Nasabah	1,644	,171	9,604	***	
KN5	<--- Keputusan_Nasabah	1,475	,155	9,528	***	
K1	<--- Kepercayaan	1,000				
K2	<--- Kepercayaan	1,334	,134	9,984	***	
K3	<--- Kepercayaan	1,128	,126	8,931	***	
K4	<--- Kepercayaan	1,395	,135	10,368	***	
K5	<--- Kepercayaan	1,356	,142	9,575	***	

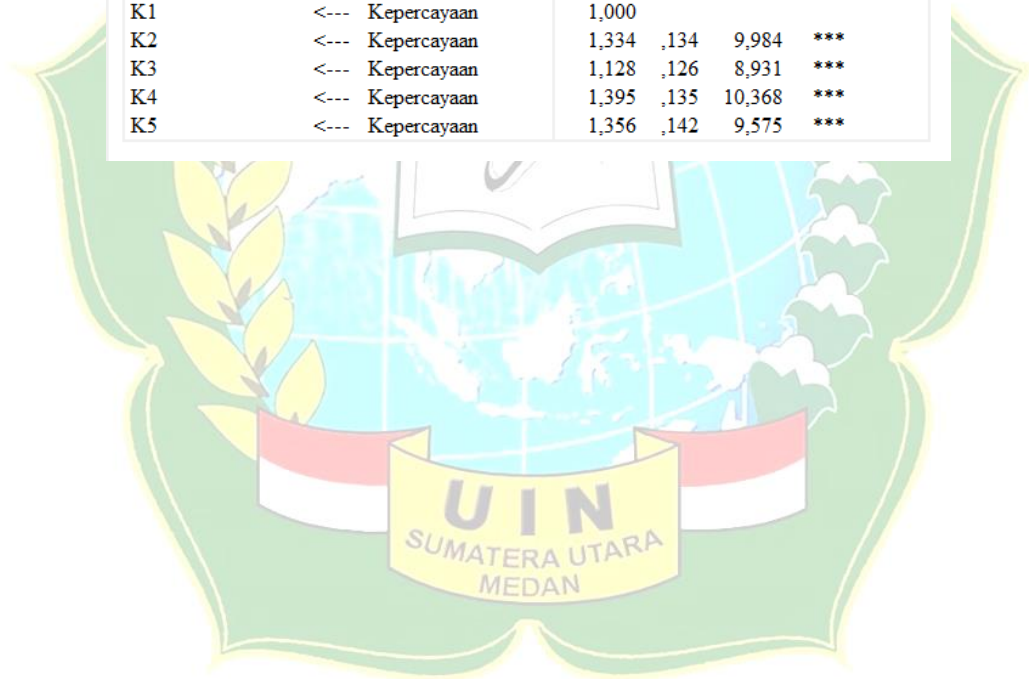

Standardized Regression Weights: (Group number 1 - Default model)

		Estimate
Sikap	<--- Religiusitas	,190
Kepercayaan	<--- Religiusitas	,237
Keputusan_Nasabah	<--- Sikap	,160
Keputusan_Nasabah	<--- Religiusitas	,185
Keputusan_Nasabah	<--- Kepercayaan	,170
R1	<--- Religiusitas	,634
R2	<--- Religiusitas	,803
R3	<--- Religiusitas	,684
R4	<--- Religiusitas	,721
R5	<--- Religiusitas	,719
S1	<--- Sikap	,771
S3	<--- Sikap	,688
S4	<--- Sikap	,697
S5	<--- Sikap	,651
KN1	<--- Keputusan_Nasabah	,588
KN2	<--- Keputusan_Nasabah	,717
KN3	<--- Keputusan_Nasabah	,782
KN4	<--- Keputusan_Nasabah	,947
KN5	<--- Keputusan_Nasabah	,929
K1	<--- Kepercayaan	,653
K2	<--- Kepercayaan	,841
K3	<--- Kepercayaan	,730
K4	<--- Kepercayaan	,891
K5	<--- Kepercayaan	,796

Variances: (Group number 1 - Default model)

	Estimate	S.E.	C.R.	P	Label
Religiusitas	,756	,163	4,639	***	
z1	,902	,160	5,630	***	
z2	,770	,155	4,964	***	
z3	,614	,138	4,432	***	
e1	1,123	,128	8,762	***	
e2	,716	,108	6,649	***	
e3	1,124	,134	8,378	***	
e4	,920	,115	7,993	***	
e5	,958	,119	8,026	***	
e6	,638	,103	6,221	***	
e8	,793	,103	7,673	***	
e9	,868	,115	7,556	***	
e10	,986	,122	8,115	***	
e16	1,319	,136	9,683	***	
e17	,793	,084	9,383	***	
e18	,653	,072	9,082	***	
e19	,217	,047	4,588	***	
e20	,240	,042	5,726	***	
e11	1,098	,119	9,217	***	
e12	,599	,081	7,384	***	
e13	,909	,103	8,799	***	
e14	,413	,070	5,938	***	
e15	,866	,106	8,161	***	

Squared Multiple Correlations: (Group number 1 - Default model)

	Estimate
Kepercayaan	,056
Sikap	,036
Keputusan_Nasabah	,117
K5	,634
K4	,793
K3	,533
K2	,708
K1	,426
KN5	,863
KN4	,896
KN3	,611
KN2	,513
KN1	,345
S5	,423
S4	,485
S3	,474
S1	,595
R5	,516
R4	,520
R3	,468
R2	,645
R1	,402

Total Effects (Group number 1 - Default model)

	Religiusitas	Kepercayaan	Sikap	Keputusan_Nasabah
Kepercayaan	,247	,000	,000	,000
Sikap	,212	,000	,000	,000
Keputusan_Nasabah	,245	,157	,138	,000
K5	,334	1,356	,000	,000
K4	,344	1,395	,000	,000
K3	,278	1,128	,000	,000
K2	,329	1,334	,000	,000
K1	,247	1,000	,000	,000
KN5	,362	,232	,204	1,475
KN4	,403	,258	,227	1,644
KN3	,298	,191	,168	1,214
KN2	,269	,172	,151	1,097
KN1	,245	,157	,138	1,000
S5	,186	,000	,880	,000
S4	,198	,000	,935	,000
S3	,185	,000	,874	,000
S1	,212	,000	1,000	,000
R5	1,163	,000	,000	,000
R4	1,149	,000	,000	,000
R3	1,144	,000	,000	,000
R2	1,313	,000	,000	,000
R1	1,000	,000	,000	,000



Standardized Total Effects (Group number 1 - Default model)

	Religiusitas	Kepercayaan	Sikap	Keputusan_Nasabah
Kepercayaan	,237	,000	,000	,000
Sikap	,190	,000	,000	,000
Keputusan_Nasabah	,256	,170	,160	,000
K5	,189	,796	,000	,000
K4	,211	,891	,000	,000
K3	,173	,730	,000	,000
K2	,200	,841	,000	,000
K1	,155	,653	,000	,000
KN5	,238	,158	<u>,149</u>	,929
KN4	,242	,161	,152	,947
KN3	,200	,133	,125	,782
KN2	,183	,122	,115	,717
KN1	,150	,100	,094	,588
S5	,124	,000	,651	,000
S4	,133	,000	,697	,000
S3	,131	,000	,688	,000
S1	,147	,000	,771	,000
R5	,719	,000	,000	,000
R4	,721	,000	,000	,000
R3	,684	,000	,000	,000
R2	,803	,000	,000	,000
R1	,634	,000	,000	,000



Direct Effects (Group number 1 - Default model)

	Religiusitas	Kepercayaan	Sikap	Keputusan_Nasabah
Kepercayaan	,247	,000	,000	,000
Sikap	,212	,000	,000	,000
Keputusan_Nasabah	,177	,157	,138	,000
K5	,000	1,356	,000	,000
K4	,000	1,395	,000	,000
K3	,000	1,128	,000	,000
K2	,000	1,334	,000	,000
K1	,000	1,000	,000	,000
KN5	,000	,000	,000	1,475
KN4	,000	,000	,000	1,644
KN3	,000	,000	,000	1,214
KN2	,000	,000	,000	1,097
KN1	,000	,000	,000	1,000
S5	,000	,000	,880	,000
S4	,000	,000	,935	,000
S3	,000	,000	,874	,000
S1	,000	,000	1,000	,000
R5	1,163	,000	,000	,000
R4	1,149	,000	,000	,000
R3	1,144	,000	,000	,000
R2	1,313	,000	,000	,000
R1	1,000	,000	,000	,000



Standardized Direct Effects (Group number 1 - Default model)

	Religiusitas	Kepercayaan	Sikap	Keputusan_Nasabah
Kepercayaan	,237	,000	,000	,000
Sikap	,190	,000	,000	,000
Keputusan_Nasabah	,185	,170	,160	,000
K5	,000	,796	,000	,000
K4	,000	,891	,000	,000
K3	,000	,730	,000	,000
K2	,000	,841	,000	,000
K1	,000	,653	,000	,000
KN5	,000	,000	,000	,929
KN4	,000	,000	,000	,947
KN3	,000	,000	,000	,782
KN2	,000	,000	,000	,717
KN1	,000	,000	,000	,588
S5	,000	,000	,651	,000
S4	,000	,000	,697	,000
S3	,000	,000	,688	,000
S1	,000	,000	,771	,000
R5	,719	,000	,000	,000
R4	,721	,000	,000	,000
R3	,684	,000	,000	,000
R2	,803	,000	,000	,000
R1	,634	,000	,000	,000



Indirect Effects (Group number 1 - Default model)

	Religiusitas	Kepercayaan	Sikap	Keputusan_Nasabah
Kepercayaan	,000	,000	,000	,000
Sikap	,000	,000	,000	,000
Keputusan_Nasabah	,068	,000	,000	,000
K5	,334	,000	,000	,000
K4	,344	,000	,000	,000
K3	,278	,000	,000	,000
K2	,329	,000	,000	,000
K1	,247	,000	,000	,000
KN5	,362	,232	,204	,000
KN4	,403	,258	,227	,000
KN3	,298	,191	,168	,000
KN2	,269	,172	,151	,000
KN1	,245	,157	,138	,000
S5	,186	,000	,000	,000
S4	,198	,000	,000	,000
S3	,185	,000	,000	,000
S1	,212	,000	,000	,000
R5	,000	,000	,000	,000
R4	,000	,000	,000	,000
R3	,000	,000	,000	,000
R2	,000	,000	,000	,000
R1	,000	,000	,000	,000



Standardized Indirect Effects (Group number 1 - Default model)

	Religiusitas	Kepercayaan	Sikap	Keputusan_Nasabah
Kepercayaan	,000	,000	,000	,000
Sikap	,000	,000	,000	,000
Keputusan_Nasabah	,071	,000	<u>,000</u>	,000
K5	,189	,000	,000	,000
K4	,211	,000	,000	,000
K3	,173	,000	,000	,000
K2	,200	,000	,000	,000
K1	,155	,000	,000	,000
KN5	,238	,158	,149	,000
KN4	,242	,161	,152	,000
KN3	,200	,133	,125	,000
KN2	,183	,122	,115	,000
KN1	,150	,100	,094	,000
S5	,124	,000	,000	,000
S4	,133	,000	,000	,000
S3	,131	,000	,000	,000
S1	,147	,000	,000	,000
R5	,000	,000	,000	,000
R4	,000	,000	,000	,000
R3	,000	,000	,000	,000
R2	,000	,000	,000	,000
R1	,000	,000	,000	,000



Normalitas

Assessment of normality (Group number 1)

Variable	min	max	skew	c.r.	kurtosis	c.r.
K5	1,000	5,000	-,117	-,678	-1,559	-4,501
K4	1,000	5,000	,080	,460	-1,388	-4,007
K3	1,000	5,000	,118	,683	-1,341	-3,870
K2	1,000	5,000	,233	1,345	-1,403	-4,051
K1	1,000	5,000	,075	,434	-1,340	-3,868
KN5	1,000	5,000	-,048	-,274	-1,093	-3,154
KN4	1,000	5,000	-,088	-,507	-1,411	-4,073
KN3	1,000	5,000	-,420	-2,424	-1,085	-3,132
KN2	1,000	5,000	-,314	-1,812	-1,070	-3,090
KN1	1,000	5,000	-,358	-2,067	-1,289	-3,720
S5	1,000	5,000	-,129	-,745	-1,127	-3,252
S4	1,000	5,000	-,407	-2,351	-,998	-2,880
S3	1,000	5,000	-,419	-2,421	-,740	-2,135
S1	1,000	5,000	-,316	-1,825	-,965	-2,785
R5	1,000	5,000	-,375	-2,166	-1,190	-3,435
R4	1,000	5,000	-,110	-,633	-1,258	-3,631
R3	1,000	5,000	-,134	-,774	-1,349	-3,894
R2	1,000	5,000	-,230	-1,327	-1,279	-3,693
R1	1,000	5,000	-,317	-1,829	-1,144	-3,303
Multivariate					13,019	3,259

Multikolinearitas

Sample Covariances (Group number 1)

	K5	K4	K3	K2	K1	KN5	KN4	KN3	KN2	KN1	S5	S4	S3	S1	R5	R4	R3	R2	R1
K5	2,365																		
K4	1,577	2,001																	
K3	1,204	1,277	1,947																
K2	1,443	1,507	1,267	2,050															
K1	1,092	1,107	,920	1,153	1,914														
KN5	,307	,327	,148	,236	,239	1,748													
KN4	,444	,405	,213	,296	,319	1,716	2,092												
KN3	,320	,178	,239	,367	,220	1,193	1,356	1,675											
KN2	,405	,230	,218	,300	,317	1,041	1,204	1,150	1,628										
KN1	,466	,306	,261	,386	,179	,958	1,038	1,062	1,275	2,013									
S5	-,104	-,137	-,172	-,209	,064	,250	,081	,219	,249	,029	1,710								
S4	-,090	-,059	-,079	-,006	-,023	,137	,161	,295	,352	,208	,777	1,686							
S3	-,133	,072	-,051	-,020	,146	,340	,283	,167	,247	,081	,667	,808	1,508						
S1	,057	,037	,097	,031	,140	,212	,178	,308	,339	,196	,872	,840	,808	1,574					
R5	,425	,486	,455	,419	,233	,266	,303	,345	,249	,321	-,046	,189	,175	,207	1,980				
R4	,212	,231	,330	,137	-,026	,218	,254	,278	,257	,275	,042	,327	,285	,296	,915	1,918			
R3	,198	,113	,150	-,083	-,059	,366	,401	,450	,348	,546	,031	,168	,129	,185	1,067	,926	2,114		
R2	,511	,459	,294	,270	,181	,362	,347	,384	,315	,482	-,003	,248	,235	,317	1,143	1,259	1,089	2,020	
R1	,346	,327	,409	,205	,174	,259	,340	,372	,289	,311	-,102	,057	,081	,188	,946	,851	1,006	,880	1,879

Condition number = 60,527

Eigenvalues

3,778 5,962 4,719 3,643 1,427 1,278 1,141 1,045 ,991 ,905 ,876 ,797 ,685 ,615 ,578 ,489 ,397 ,334 ,162

Determinant of sample covariance matrix = 3,479

Activate Windows



Outlier Data

Observations farthest from the centroid (Mahalanobis distance) (Group number 1)

Observation number	Mahalanobis d-squared	p1	p2
139	39,941	,003	,487
179	35,444	,012	,708
135	35,418	,012	,454
197	34,480	,016	,403
109	34,470	,016	,224
160	34,331	,017	,122
195	34,331	,017	,053
150	33,744	,020	,046
189	33,744	,020	,018
39	33,721	,020	,007
101	32,961	,024	,010
44	32,769	,026	,006
59	32,107	,030	,009
166	31,996	,031	,004
149	31,381	,037	,007
124	29,930	,053	,065
119	29,925	,053	,037
162	29,758	,055	,028
148	29,445	,059	,030
71	28,962	,067	,046
169	28,113	,081	,137
87	27,905	,085	,132
130	27,808	,087	,105
112	27,685	,090	,088
47	27,295	,098	,123
159	27,136	,102	,114
122	27,018	,104	,098
26	26,876	,108	,089
32	26,588	,115	,110



32	26,588	,115	,110
181	26,011	,130	,226
146	25,873	,134	,215
157	25,762	,137	,197
21	25,757	,137	,148
155	25,458	,146	,193
194	25,458	,146	,145
46	25,185	,155	,183
129	25,118	,157	,158
75	25,037	,159	,139
72	24,584	,175	,250
103	24,373	,182	,283
37	23,934	,199	,439
53	23,901	,200	,389
3	23,622	,211	,473
94	23,541	,214	,450
188	23,379	,221	,474
68	23,305	,224	,449
114	22,978	,238	,571
70	22,976	,238	,506
14	22,956	,239	,452
175	22,956	,239	,388
18	22,803	,246	,412
174	22,724	,250	,395
133	22,698	,251	,348
49	22,253	,272	,550
108	22,218	,274	,508
123	22,131	,278	,499
170	22,131	,278	,436
180	22,131	,278	,375

41	22,111	,279	,329
92	21,973	,286	,351
93	21,762	,296	,419
40	21,657	,302	,425
145	21,288	,321	,600
27	21,018	,336	,706
127	21,001	,337	,663
17	20,945	,340	,641
19	20,939	,340	,588
118	20,854	,345	,585
81	20,675	,355	,642
147	20,527	,364	,679
156	20,525	,364	,626
15	20,476	,366	,601
176	20,476	,366	,544
117	20,457	,368	,498
99	20,419	,370	,466
132	20,226	,381	,539
107	20,208	,382	,494
142	20,177	,384	,457
185	20,177	,384	,400
11	20,155	,385	,360
8	20,150	,386	,311
56	20,091	,389	,296
116	19,792	,407	,438
165	19,763	,409	,401
200	19,763	,409	,347
97	19,719	,412	,323
100	19,618	,418	,336
113	19,585	,420	,306

113	19,585	,420	,306
153	19,565	,421	,270
66	19,074	,452	,551
152	19,044	,454	,516
191	19,044	,454	,460
74	19,008	,456	,430
128	18,999	,457	,381
95	18,918	,462	,383
136	18,853	,466	,375
96	18,729	,474	,408
1	18,675	,478	,392
84	18,666	,478	,345
7	18,504	,489	,406



Modification Indise

Modification Indices (Group number 1 - Default model)

Covariances: (Group number 1 - Default model)

	M.I.	Par Change
e19 <--> z1	4,928	-,105
e19 <--> e20	8,839	,067
e18 <--> e14	14,089	-,179
e18 <--> e12	10,760	,172
e18 <--> e20	4,793	-,076
e17 <--> z1	4,829	,152
e17 <--> e14	5,422	-,121
e17 <--> e20	10,587	-,124
e17 <--> e19	4,756	-,087
e17 <--> e18	22,459	,259
e16 <--> e19	13,424	-,188
e16 <--> e18	12,412	,245
e16 <--> e17	54,548	,558
e10 <--> Religiusitas	6,162	-,178
e10 <--> e20	7,760	,127
e10 <--> e19	6,589	-,123
e9 <--> e20	6,949	-,115
e8 <--> e15	5,661	-,168
e8 <--> e20	4,977	,093
e8 <--> e18	7,266	-,158
e3 <--> z2	6,080	-,184
e3 <--> e12	4,593	-,152
e2 <--> e13	4,103	-,144
e2 <--> e4	6,475	,181
e1 <--> e2	4,639	-,166



Full Model Setelah Modifikasi

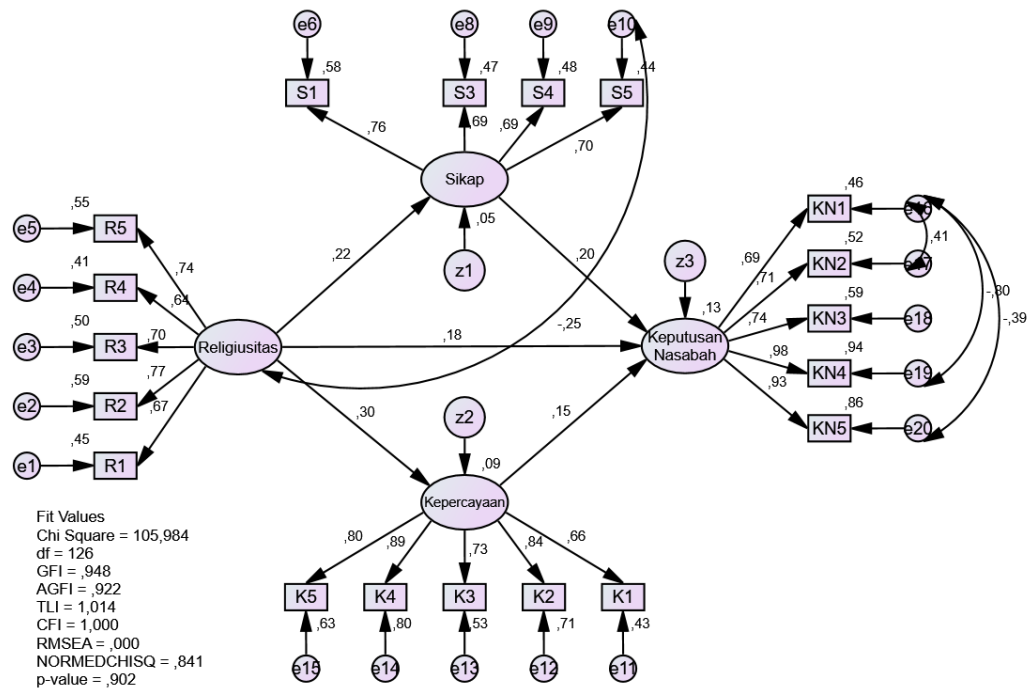

Regression Weights: (Group number 1 - Default model)

			Estimate	S.E.	C.R.	P	Label
Sikap	<---	Religiusitas	,232	,092	2,516	,012	
Kepercayaan	<---	Religiusitas	,295	,087	3,373	***	
Keputusan_Nasabah	<---	Sikap	,196	,085	2,301	,021	
Keputusan_Nasabah	<---	Religiusitas	,183	,085	2,158	,031	
Keputusan_Nasabah	<---	Kepercayaan	,163	,080	2,045	,041	
R1	<---	Religiusitas	1,000				
R2	<---	Religiusitas	1,196	,153	7,827	***	
R3	<---	Religiusitas	1,109	,136	8,165	***	
R4	<---	Religiusitas	,957	,138	6,916	***	
R5	<---	Religiusitas	1,131	,146	7,735	***	
S1	<---	Sikap	1,000				
S3	<---	Sikap	,880	,102	8,594	***	
S4	<---	Sikap	,937	,109	8,587	***	
S5	<---	Sikap	,960	,115	8,328	***	
KN1	<---	Keputusan_Nasabah	1,000				
KN2	<---	Keputusan_Nasabah	1,000				
KN3	<---	Keputusan_Nasabah	1,000				
KN4	<---	Keputusan_Nasabah	1,526	,087	17,486	***	
KN5	<---	Keputusan_Nasabah	1,303	,077	16,986	***	
K1	<---	Kepercayaan	1,000				
K2	<---	Kepercayaan	1,331	,130	10,203	***	
K3	<---	Kepercayaan	1,128	,124	9,093	***	
K4	<---	Kepercayaan	1,387	,131	10,581	***	
K5	<---	Kepercayaan	1,351	,138	9,756	***	



		Estimate
Sikap	<--- Religiusitas	,224
Kepercayaan	<--- Religiusitas	,300
Keputusan_Nasabah	<--- Sikap	,197
Keputusan_Nasabah	<--- Religiusitas	,178
Keputusan_Nasabah	<--- Kepercayaan	,155
R1	<--- Religiusitas	,673
R2	<--- Religiusitas	,769
R3	<--- Religiusitas	,704
R4	<--- Religiusitas	,638
R5	<--- Religiusitas	,741
S1	<--- Sikap	,764
S3	<--- Sikap	,687
S4	<--- Sikap	,693
S5	<--- Sikap	,704
KN1	<--- Keputusan_Nasabah	,688
KN2	<--- Keputusan_Nasabah	,713
KN3	<--- Keputusan_Nasabah	,737
KN4	<--- Keputusan_Nasabah	,985
KN5	<--- Keputusan_Nasabah	,927
K1	<--- Kepercayaan	,655
K2	<--- Kepercayaan	,841
K3	<--- Kepercayaan	,731
K4	<--- Kepercayaan	,892
K5	<--- Kepercayaan	,796

Covariances: (Group number 1 - Default model)

	Estimate	S.E.	C.R.	P	Label
e16 <--> e20	-,198	,070	-2,820	,005	
e10 <--> Religiusitas	-,227	,084	-2,713	,007	
e16 <--> e17	,384	,085	4,516	***	
e16 <--> e19	-,301	,076	-3,946	***	
e19 <--> z1	-,117	,056	-2,078	,038	
e18 <--> Religiusitas	,146	,058	2,529	,011	
e18 <--> e14	-,101	,048	-2,097	,036	
e18 <--> e12	,130	,054	2,398	,016	
e17 <--> z1	,074	,068	1,092	,275	
e17 <--> e11	,081	,068	1,179	,238	
e17 <--> e18	,222	,052	4,287	***	
e16 <--> z1	-,089	,088	-1,005	,315	
e16 <--> e11	-,074	,088	-,841	,400	
e10 <--> e20	,053	,067	,800	,424	
e10 <--> e19	-,048	,071	-,677	,499	
e9 <--> e20	-,096	,046	-2,098	,036	
e8 <--> e15	-,173	,071	-2,425	,015	
e8 <--> e19	,031	,044	,700	,484	
e3 <--> z2	-,222	,078	-2,840	,005	
e2 <--> e13	-,157	,069	-2,265	,024	
e2 <--> e4	,316	,108	2,932	,003	
e1 <--> e3	,054	,112	,480	,631	
e1 <--> e2	-,121	,086	-1,402	,161	

	Estimate
e16 <--> e20	-,386
e10 <--> Religiusitas	-,251
e16 <--> e17	,407
e16 <--> e19	-,797
e19 <--> z1	-,338
e18 <--> Religiusitas	,191
e18 <--> e14	-,192
e18 <--> e12	,202
e17 <--> z1	,086
e17 <--> e11	,083
e17 <--> e18	,291
e16 <--> z1	-,093
e16 <--> e11	-,069
e10 <--> e20	,108
e10 <--> e19	-,132
e9 <--> e20	-,205
e8 <--> e15	-,208
e8 <--> e19	,094
e3 <--> z2	-,248
e2 <--> e13	-,180
e2 <--> e4	,323
e1 <--> e3	,051
e1 <--> e2	-,129



Variances: (Group number 1 - Default model)

	Estimate	S.E.	C.R.	P	Label
Religiusitas	,853	,188	4,546	***	
z1	,873	,156	5,597	***	
z2	,750	,150	5,006	***	
z3	,791	,112	7,094	***	
e1	1,029	,145	7,109	***	
e2	,842	,134	6,288	***	
e3	1,068	,145	7,359	***	
e4	1,139	,139	8,176	***	
e5	,894	,122	7,333	***	
e6	,655	,100	6,546	***	
e8	,797	,102	7,800	***	
e9	,874	,113	7,721	***	
e10	,964	,121	7,995	***	
e16	1,046	,140	7,460	***	
e17	,852	,088	9,678	***	
e18	,683	,070	9,701	***	
e19	,137	,051	2,668	,008	
e20	,252	,045	5,624	***	
e11	1,096	,119	9,232	***	
e12	,604	,080	7,499	***	
e13	,912	,103	8,821	***	
e14	,405	,067	6,015	***	
e15	,869	,106	8,217	***	

Squared Multiple Correlations: (Group number 1 - Default model)

	Estimate
Kepercayaan	,090
Sikap	,050
Keputusan_Nasabah	,130
K5	,634
K4	,797
K3	,535
K2	,707
K1	,429
KN5	,860
KN4	,937
KN3	,592
KN2	,524
KN1	,456
S5	,436
S4	,480
S3	,471
S1	,584
R5	,550
R4	,407
R3	,495
R2	,592
R1	,453

Total Effects (Group number 1 - Default model)

	Religiusitas	Kepercayaan	Sikap	Keputusan_Nasabah
Kepercayaan	,295	,000	,000	,000
Sikap	,232	,000	,000	,000
Keputusan_Nasabah	,277	,163	,196	,000
K5	,398	1,351	,000	,000
K4	,409	1,387	,000	,000
K3	,333	1,128	,000	,000
K2	,392	1,331	,000	,000
K1	,295	1,000	,000	,000
KN5	,361	,212	,255	1,303
KN4	,422	,248	,299	1,526
KN3	,277	,163	,196	1,000
KN2	,277	,163	,196	1,000
KN1	,277	,163	,196	1,000
S5	,223	,000	,960	,000
S4	,217	,000	,937	,000
S3	,204	,000	,880	,000
S1	,232	,000	1,000	,000
R5	1,131	,000	,000	,000
R4	,957	,000	,000	,000
R3	1,109	,000	,000	,000
R2	1,196	,000	,000	,000
R1	1,000	,000	,000	,000



Standardized Total Effects (Group number 1 - Default model)

	Religiusitas	Kepercayaan	Sikap	Keputusan_Nasabah
Kepercayaan	,300	,000	,000	,000
Sikap	,224	,000	,000	,000
Keputusan_Nasabah	,268	,155	,197	,000
K5	,239	,796	,000	,000
K4	,268	,892	,000	,000
K3	,219	,731	,000	,000
K2	,252	,841	,000	,000
K1	,197	,655	,000	,000
KN5	,249	,144	,182	,927
KN4	,264	,153	,194	,985
KN3	,198	,114	,145	,737
KN2	,191	,110	,140	,713
KN1	,185	,107	<u>.135</u>	,688
S5	,157	,000	,704	,000
S4	,155	,000	,693	,000
S3	,154	,000	,687	,000
S1	,171	,000	,764	,000
R5	,741	,000	,000	,000
R4	,638	,000	,000	,000
R3	,704	,000	,000	,000
R2	,769	,000	,000	,000
R1	,673	,000	,000	,000



	Religiusitas	Kepercayaan	Sikap	Keputusan_Nasabah
tree Kepercayaan	,295	,000	,000	,000
Sikap	,232	,000	,000	,000
Keputusan_Nasabah	,183	,163	,196	,000
K5	,000	1,351	,000	,000
K4	,000	1,387	,000	,000
K3	,000	1,128	,000	,000
K2	,000	1,331	,000	,000
K1	,000	1,000	,000	,000
KN5	,000	,000	,000	1,303
KN4	,000	,000	,000	1,526
KN3	,000	,000	,000	1,000
KN2	,000	,000	,000	1,000
KN1	,000	,000	,000	1,000
S5	,000	,000	,960	,000
S4	,000	,000	,937	,000
S3	,000	,000	,880	,000
S1	,000	,000	1,000	,000
R5	1,131	,000	,000	,000
R4	,957	,000	,000	,000
R3	1,109	,000	,000	,000
R2	1,196	,000	,000	,000
R1	1,000	,000	,000	,000



Standardized Direct Effects (Group number 1 - Default model)

	Religiusitas	Kepercayaan	Sikap	Keputusan_Nasabah
Kepercayaan	,300	,000	,000	,000
Sikap	,224	,000	,000	,000
Keputusan_Nasabah	,178	,155	,197	,000
K5	,000	,796	,000	,000
K4	,000	,892	,000	,000
K3	,000	,731	,000	,000
K2	,000	,841	,000	,000
K1	,000	,655	,000	,000
KN5	,000	,000	,000	,927
KN4	,000	,000	,000	,985
KN3	,000	,000	,000	,737
KN2	,000	,000	,000	,713
KN1	,000	,000	,000	,688
S5	,000	,000	,704	,000
S4	,000	,000	,693	,000
S3	,000	,000	,687	,000
S1	,000	,000	,764	,000
R5	,741	,000	,000	,000
R4	,638	,000	,000	,000
R3	,704	,000	,000	,000
R2	,769	,000	,000	,000
R1	,673	,000	,000	,000



Indirect Effects (Group number 1 - Default model)

	Religiusitas	Kepercayaan	Sikap	Keputusan_Nasabah
Kepercayaan	,000	,000	,000	,000
Sikap	,000	,000	,000	,000
Keputusan_Nasabah	,093	,000	,000	,000
K5	,398	,000	,000	,000
K4	,409	,000	,000	,000
K3	,333	,000	,000	,000
K2	,392	,000	,000	,000
K1	,295	,000	,000	,000
KN5	,361	,212	,255	,000
KN4	,422	,248	,299	,000
KN3	,277	,163	,196	,000
KN2	,277	,163	,196	,000
KN1	,277	,163	,196	,000
S5	,223	,000	,000	,000
S4	,217	,000	,000	,000
S3	,204	,000	,000	,000
S1	,232	,000	,000	,000
R5	,000	,000	,000	,000
R4	,000	,000	,000	,000
R3	,000	,000	,000	,000
R2	,000	,000	,000	,000
R1	,000	,000	,000	,000



Standardized Indirect Effects (Group number 1 - Default model)

	Religiusitas	Kepercayaan	Sikap	Keputusan_Nasabah
Kepercayaan	,000	,000	,000	,000
Sikap	,000	,000	,000	,000
Keputusan_Nasabah	,090	,000	,000	,000
K5	,239	,000	,000	,000
K4	,268	,000	,000	,000
K3	,219	,000	,000	,000
K2	,252	,000	,000	,000
K1	,197	,000	,000	,000
KN5	,249	,144	,182	,000
KN4	,264	,153	,194	,000
KN3	,198	,114	,145	,000
KN2	,191	,110	,140	,000
KN1	,185	,107	,135	,000
S5	,157	,000	,000	,000
S4	,155	,000	,000	,000
S3	,154	,000	,000	,000
S1	,171	,000	,000	,000
R5	,000	,000	,000	,000
R4	,000	,000	,000	,000
R3	,000	,000	,000	,000
R2	,000	,000	,000	,000
R1	,000	,000	,000	,000



Normalitas

Assessment of normality (Group number 1)

Variable	min	max	skew	c.r.	kurtosis	c.r.
K5	1,000	5,000	-,117	-,678	-1,559	-4,501
K4	1,000	5,000	,080	,460	-1,388	-4,007
K3	1,000	5,000	,118	,683	-1,341	-3,870
K2	1,000	5,000	,233	1,345	-1,403	-4,051
K1	1,000	5,000	,075	,434	-1,340	-3,868
KN5	1,000	5,000	-,048	-,274	-1,093	-3,154
KN4	1,000	5,000	-,088	-,507	-1,411	-4,073
KN3	1,000	5,000	-,420	-2,424	-1,085	-3,132
KN2	1,000	5,000	-,314	-1,812	-1,070	-3,090
KN1	1,000	5,000	-,358	-2,067	-1,289	-3,720
S5	1,000	5,000	-,129	-,745	-1,127	-3,252
S4	1,000	5,000	-,407	-2,351	-,998	-2,880
S3	1,000	5,000	-,419	-2,421	-,740	-2,135
S1	1,000	5,000	-,316	-1,825	-,965	-2,785
R5	1,000	5,000	-,375	-2,166	-1,190	-3,435
R4	1,000	5,000	-,110	-,633	-1,258	-3,631
R3	1,000	5,000	-,134	-,774	-1,349	-3,894
R2	1,000	5,000	-,230	-1,327	-1,279	-3,693
R1	1,000	5,000	-,317	-1,829	-1,144	-3,303
Multivariate					13,019	2,259

Multilinearitas

Sample Covariances (Group number 1)

	K5	K4	K3	K2	K1	KN5	KN4	KN3	KN2	KN1	S5	S4	S3	S1	R5	R4	R3	R2	R1	
K5	2,365																			
K4	1,577	2,001																		
K3	1,204	1,277	1,947																	
K2	1,443	1,507	1,267	2,050																
K1	1,092	1,107	,920	1,153	1,914															
KN5	,307	,327	,148	,236	,239	1,748														
KN4	,444	,405	,213	,296	,319	1,716	2,092													
KN3	,320	,178	,239	,367	,220	1,193	1,356	1,675												
KN2	,405	,230	,218	,300	,317	1,041	1,204	1,150	1,628											
KN1	,466	,306	,261	,386	,179	,958	1,038	1,062	1,275	2,013										
S5	-,104	-,137	-,172	-,209	,064	,250	,081	,219	,249	,029	1,710									
S4	-,090	-,059	-,079	-,006	-,023	,137	,161	,295	,352	,208	,777	1,686								
S3	-,133	,072	-,051	-,020	,146	,340	,283	,167	,247	,081	,667	,808	1,508							
S1	,057	,037	,097	,031	,140	,212	,178	,308	,339	,196	,872	,840	,808	1,574						
R5	,425	,486	,455	,419	,233	,266	,303	,345	,249	,321	-,046	,189	,175	,207	1,980					
R4	,212	,231	,330	,137	-,026	,218	,254	,278	,257	,275	,042	,327	,285	,296	,915	1,918				
R3	,198	,113	,150	-,083	-,059	,366	,401	,450	,348	,546	,031	,168	,129	,185	1,067	,926	2,114			
R2	,511	,459	,294	,270	,181	,362	,347	,384	,315	,482	-,003	,248	,235	,317	1,143	1,259	1,089	2,020		
R1	,346	,327	,409	,205	,174	,259	,340	,372	,289	,311	-,102	,057	,081	,188	,946	,851	1,006	,880	1,879	

Condition number = 60,527

Eigenvalues

9,778 5,962 4,719 3,643 1,427 1,278 1,141 1,045 ,991 ,905 ,876 ,797 ,685 ,615 ,578 ,489 ,397 ,334 ,162

Determinant of sample covariance matrix = 3,479

Activate Windows

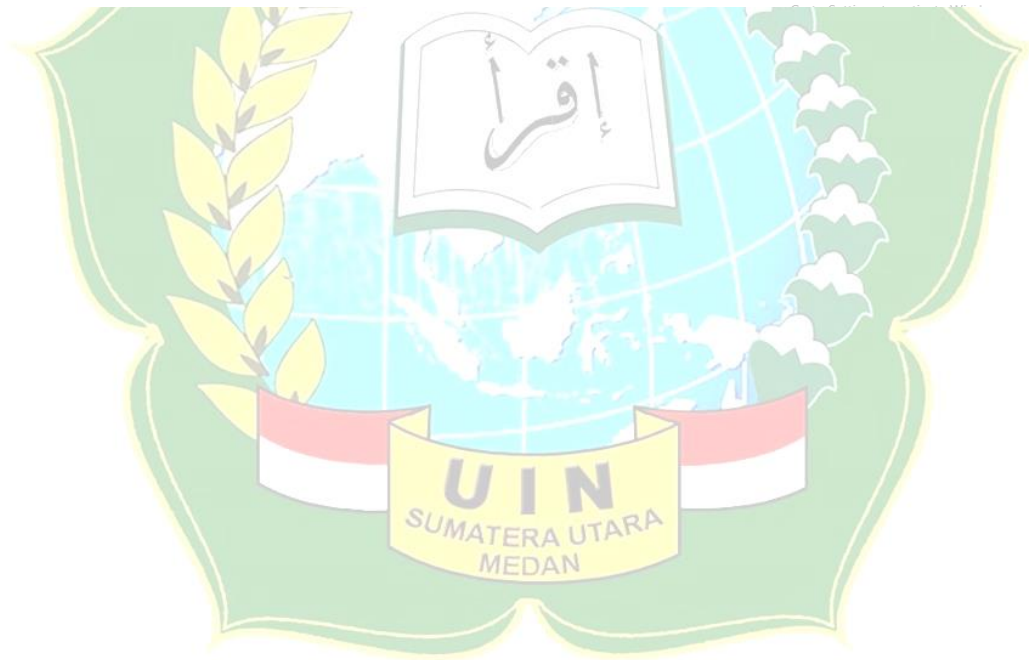

Outlier Data

Observations farthest from the centroid (Mahalanobis distance) (Group number 1)

Observation number	Mahalanobis d-squared	p1	p2
124	29,930	,053	,065
119	29,925	,053	,037
162	29,758	,055	,028
148	29,445	,059	,030
71	28,962	,067	,046
169	28,113	,081	,137
87	27,905	,085	,132
130	27,808	,087	,105
112	27,685	,090	,088
47	27,295	,098	,123
159	27,136	,102	,114
122	27,018	,104	,098
26	26,876	,108	,089
32	26,588	,115	,110
181	26,011	,130	,226
146	25,873	,134	,215
157	25,762	,137	,197
21	25,757	,137	,148
155	25,458	,146	,193
194	25,458	,146	,145
46	25,185	,155	,183
129	25,118	,157	,158
75	25,037	,159	,139
72	24,584	,175	,250
103	24,373	,182	,283
37	23,934	,199	,439
53	23,901	,200	,389
3	23,622	,211	,473
94	23,541	,214	,450
188	23,379	,221	,474
68	23,305	,224	,449
114	22,978	,238	,571

Observation number	Mahalanobis d-squared	p1	p2
70	22,976	,238	,506
14	22,956	,239	,452
175	22,956	,239	,388
18	22,803	,246	,412
174	22,724	,250	,395
133	22,698	,251	,348
49	22,253	,272	,550
108	22,218	,274	,508
123	22,131	,278	,499
170	22,131	,278	,436
180	22,131	,278	,375
41	22,111	,279	,329
92	21,973	,286	,351
93	21,762	,296	,419
40	21,657	,302	,425
145	21,288	,321	,600
27	21,018	,336	,706
127	21,001	,337	,663
17	20,945	,340	,641
19	20,939	,340	,588
118	20,854	,345	,585
81	20,675	,355	,642
147	20,527	,364	,679
156	20,525	,364	,626
15	20,476	,366	,601
176	20,476	,366	,544
117	20,457	,368	,498
99	20,419	,370	,466
132	20,226	,381	,539
107	20,208	,382	,494
142	20,177	,384	,457
185	20,177	,384	,400
11	20,155	,385	,360
8	20,150	,386	,311
56	20,091	,389	,296
116	19,792	,407	,438
165	19,763	,409	,401

Observation number	Mahalanobis d-squared	p1	p2
200	19,763	,409	,347
97	19,719	,412	,323
100	19,618	,418	,336
113	19,585	,420	,306
153	19,565	,421	,270
66	19,074	,452	,551
152	19,044	,454	,516
191	19,044	,454	,460
74	19,008	,456	,430
128	18,999	,457	,381
95	18,918	,462	,383
136	18,853	,466	,375
96	18,729	,474	,408
1	18,675	,478	,392
84	18,666	,478	,345
7	18,504	,489	,406

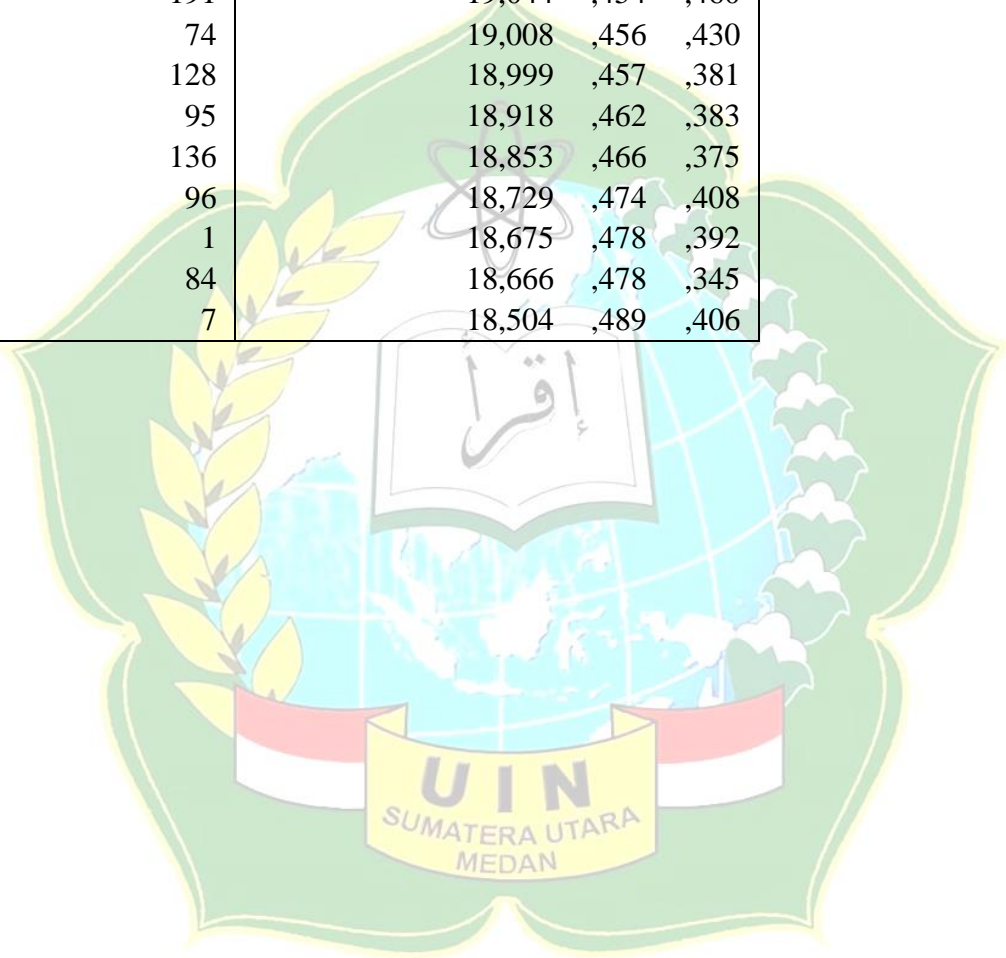

Modification Indise

Modification Indices (Group number 1 - Default model)

Covariances: (Group number 1 - Default model)

	M.I.	Par Change
e17 <--> z3	4,341	-,098

Variances: (Group number 1 - Default model)

	M.I.	Par Change
--	------	------------

Regression Weights: (Group number 1 - Default model)

	M.I.	Par Change
K2 <--- R3	4,892	-,091
KN1 <--- R3	4,538	,101
R3 <--- KN1	4,755	,123

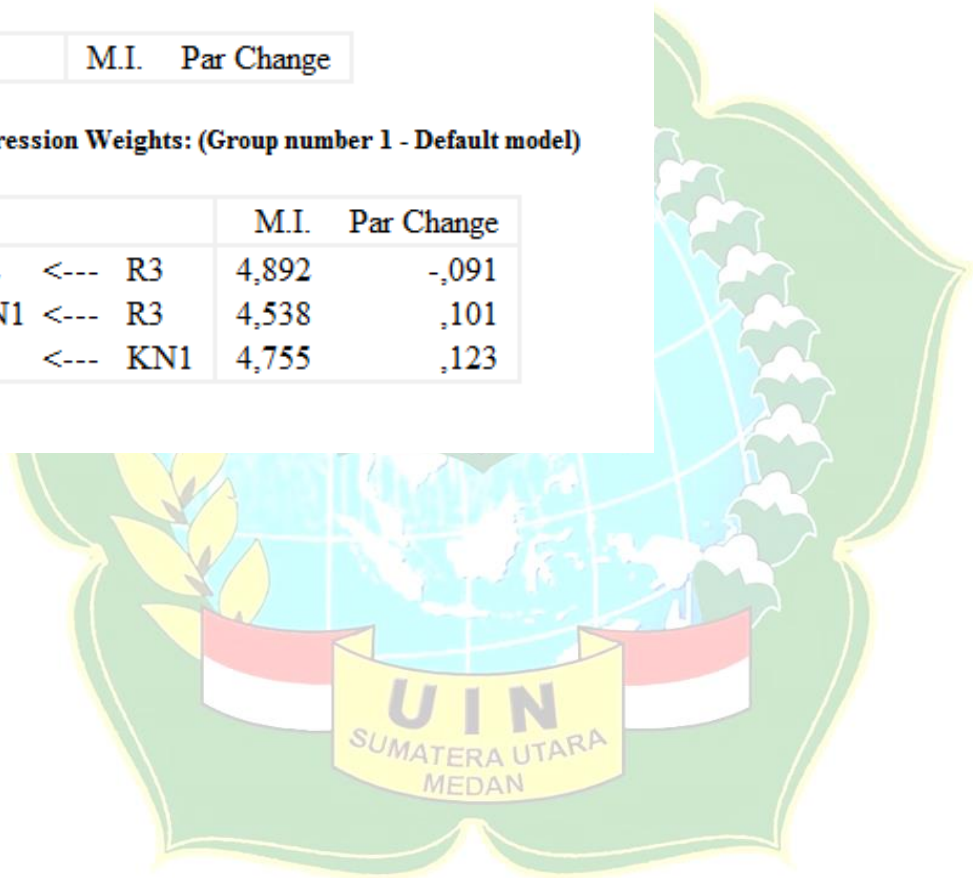

Fit Model

Model Fit Summary

CMIN

Model	NPAR	CMIN	DF	P	CMIN/DF
Default model	64	105,984	126	,902	,841
Saturated model	190	,000	0		
Independence model	19	2125,319	171	,000	12,429

RMR, GFI

Model	RMR	GFI	AGFI	PGFI
Default model	,081	,948	,922	,629
Saturated model	,000	1,000		
Independence model	,536	,388	,320	,349

Baseline Comparisons

Model	NFI Delta1	RFI rho1	IFI Delta2	TLI rho2	CFI
Default model	,950	,932	1,010	1,014	1,000
Saturated model	1,000		1,000		1,000
Independence model	,000	,000	,000	,000	,000

Parsimony-Adjusted Measures

Model	PRATIO	PNFI	PCFI
Default model	,737	,700	,737
Saturated model	,000	,000	,000
Independence model	1,000	,000	,000

NCP

Model	NCP	LO 90	HI 90
Default model	,000	,000	6,091
Saturated model	,000	,000	,000
Independence model	1954,319	1809,386	2106,639

FMIN

Model	FMIN	F0	LO 90	HI 90
Default model	,533	,000	,000	,031
Saturated model	,000	,000	,000	,000
Independence model	10,680	9,821	9,092	10,586

RMSEA

Model	RMSEA	LO 90	HI 90	PCLOSE
Default model	,000	,000	,016	1,000
Independence model	,240	,231	,249	,000

AIC

Model	AIC	BCC	BIC	CAIC
Default model	233,984	248,286	445,077	509,077
Saturated model	380,000	422,458	1006,680	1196,680
Independence model	2163,319	2167,565	2225,987	2244,987



FMIN

Model	FMIN	F0	LO 90	HI 90
Default model	,533	,000	,000	,031
Saturated model	,000	,000	,000	,000
Independence model	10,680	9,821	9,092	10,586

RMSEA

Model	RMSEA	LO 90	HI 90	PCLOSE
Default model	,000	,000	,016	1,000
Independence model	,240	,231	,249	,000

AIC

Model	AIC	BCC	BIC	CAIC
Default model	233,984	248,286	445,077	509,077
Saturated model	380,000	422,458	1006,680	1196,680
Independence model	2163,319	2167,565	2225,987	2244,987

ECVI

Model	ECVI	LO 90	HI 90	MECVI
Default model	1,176	1,276	1,307	1,248
Saturated model	1,910	1,910	1,910	2,123
Independence model	10,871	10,143	11,636	10,892

HOELTER

Model	HOELTER .05	HOELTER .01
Default model	288	312
Independence model	19	21